

Corning® Single-use Technology

Single-use Bags, Tubing, Tank Liners, Film Types,
and Custom Configurations

CORNING



Corning® Single-use Technology

Corning® single-use systems are designed to be practical and cost-effective alternatives to rigid-walled containers. They are fabricated to match your specific application with a variety of sizes and tubing/connector configurations. These containment and delivery systems preserve the physical, chemical, and functional characteristics of sterile and process fluids. All components can be customized to match your requirements

Features and Benefits

- ▶ High-quality barrier films
- ▶ Sterile
- ▶ Gas and moisture barriers to minimize transmission of oxygen, carbon dioxide, and water vapor
- ▶ Universal connection systems
- ▶ Reduces costs associated with washing, sterilization, and SIP/CIP validations
- ▶ Reduces the risks associated with cross-contamination
- ▶ Minimal setup time
- ▶ Wide variety of standard configurations
- ▶ Easily integrated in automated systems

Industry Recognized Manufacturing Standards

- ▶ cGMP and ISO 13485 manufacturing process
- ▶ Complete documentation and traceability
- ▶ Animal-free manufacturing process

Custom Configuration Options

- ▶ 50 mL to 500L sizes
- ▶ 2D and 3D configurations (pillow and gusseted)
- ▶ Hanging designs
- ▶ Manifold systems
- ▶ Custom tubing and filter assemblies
- ▶ Cryopreservation bags
- ▶ Single-use bags for Corning HYPERStack® vessels

Applications

- ▶ Bioreactor and fermentation
- ▶ Media storage and delivery
- ▶ Seed/culture/harvest/recovery
- ▶ Separation
- ▶ Downstream processing
- ▶ Filtration
- ▶ Storage of high purity water
- ▶ Waste containment

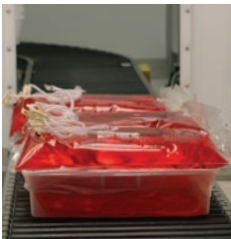

Custom Fabrication and Assembly Services

Corning offers extensive custom design services for single-use systems.

Film Materials

- ▶ Ethyl vinyl acetate (EVA)
- ▶ Ultra-low density polyethylene (ULDPE)
- ▶ Polyethylene (PE)
- ▶ Metallocene
- ▶ Polyolefin

Fittings

- ▶ Luer locks
- ▶ CPC connectors
- ▶ Sanitary fitting
- ▶ Hose barbs
- ▶ Spike components
- ▶ Steam-in-place (SIP) connectors

Tubing

- ▶ Chemically resistant, heat sealable flexible tubing
- ▶ Platinum or peroxide cured silicone
- ▶ PVC

Configuration

- ▶ Custom sizes
- ▶ Bottom ports
- ▶ 2D and 3D options
- ▶ Dip tube
- ▶ Recirculation tube

Bag Types Available

- ▶ Collection bags
- ▶ Tank liners
- ▶ Cryopreservation bags
- ▶ Cell expansion bags
- ▶ Bags for Corning® HYPERStack® vessels
- ▶ Rocker cell culture bags



COLLECTION BAGS

Corning® collection bags are available in 2D hanging configurations with multiple bag volumes and connector configurations.

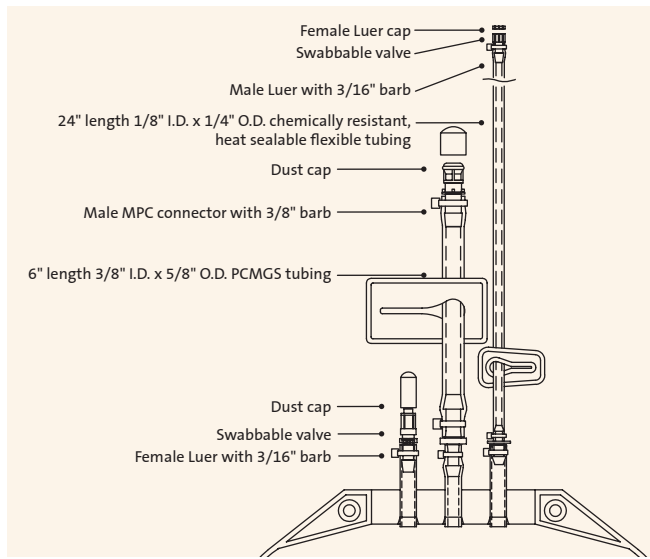

Cat. No.	Film Type	Size	Qty/Pk
91-200-01	EVA	1L	1
91-200-02	EVA	2L	1
91-200-05	EVA	5L	1
91-200-10	EVA	10L	1
91-200-20	EVA	20L	1

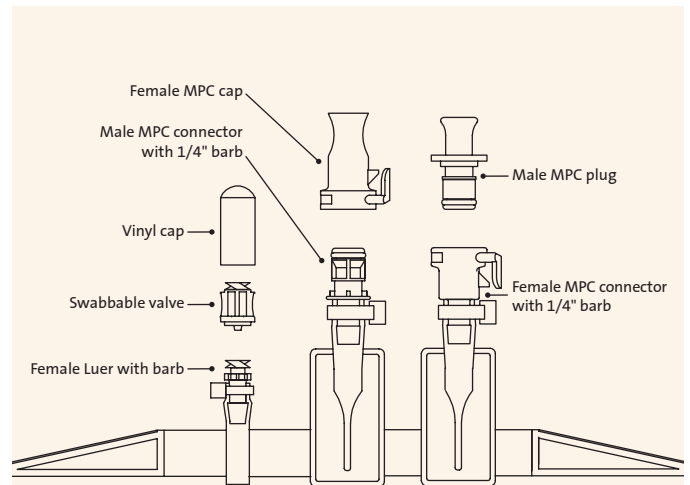

Cat. No.	Film Type	Size	Qty/Pk
91-200-36	EVA	10L	1
91-200-39	EVA	20L	1

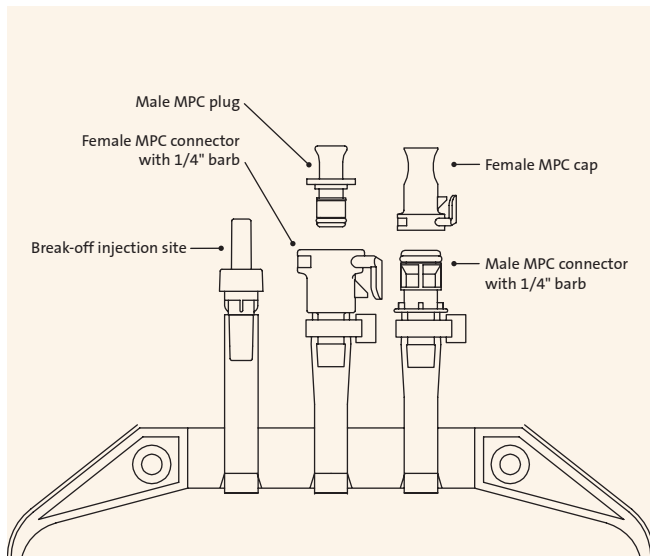

Cat. No.	Film Type	Size	Qty/Pk
91-200-41	EVA	500 mL	1
91-200-42	EVA	1L	1

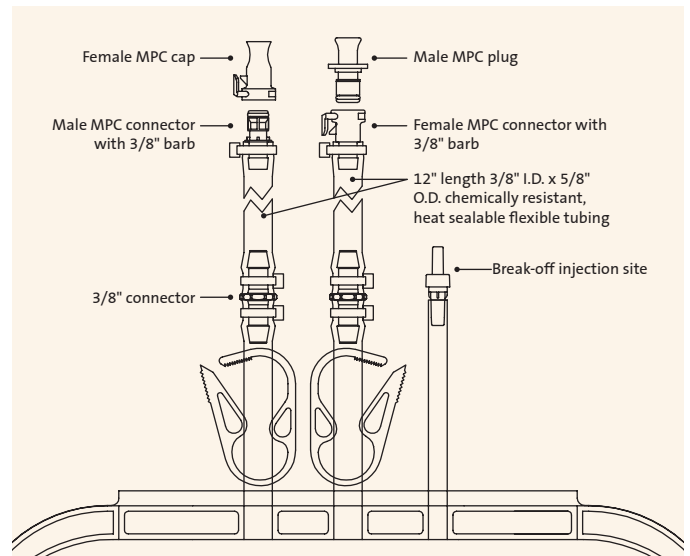

Cat. No.	Film Type	Size	Qty/Pk
91-200-43	EVA	5L	1
91-200-45	EVA	10L	1
91-200-47	EVA	20L	1
91-200-48	EVA	50L	1

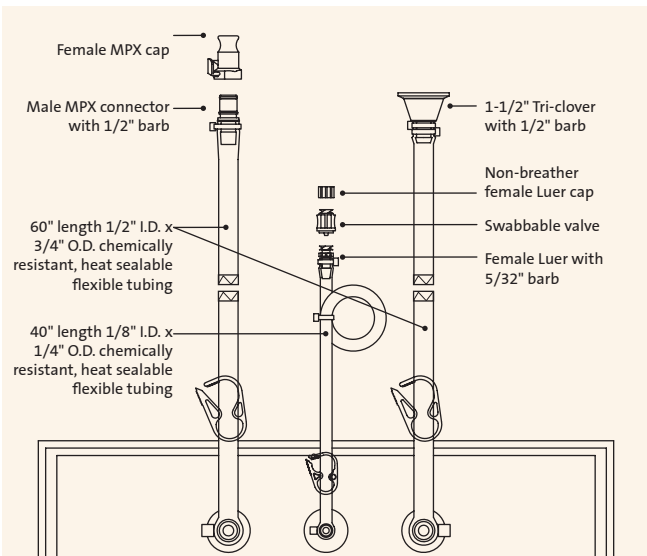

Cat. No.	Film Type	Size	Qty/Pk
91-200-82	ULDPE	100L	1
91-200-83	ULDPE	200L	1

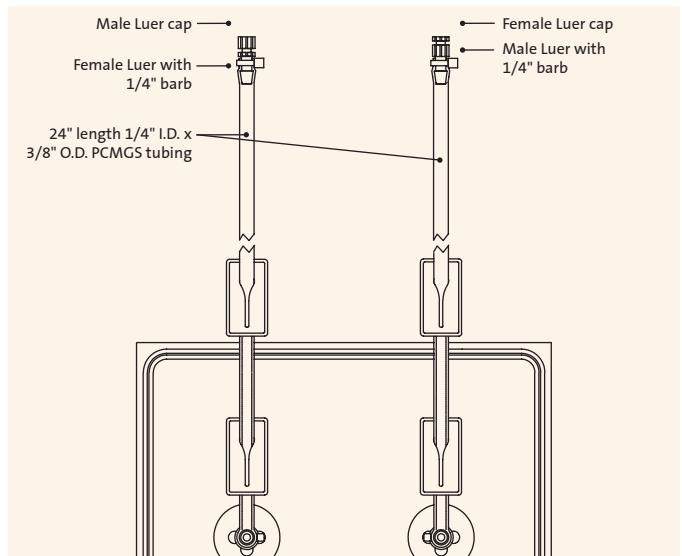

Cat. No.	Film Type	Size	Qty/Pk
91-002-MX	Metallocene	10L	1
91-001-MB	Metallocene	25L	1

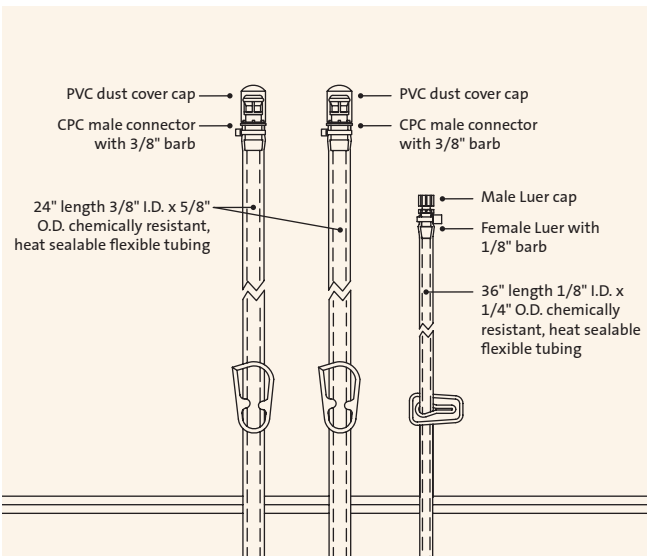

Cat. No.	Film Type	Size	Qty/Pk
91-100-30	Metallocene	50L	1
91-100-35	Metallocene	100L	1

CELL EXPANSION BAGS

Cell expansion bags are intended for the expansion and culture of non-adherent cells. The bags are made from single-web polyolefin, gas permeable film. The integrated tubing allows for functionally closed system filling, feeding, and sampling.

Features and Benefits

- ▶ Cell expansion observed with multiple cell models
- ▶ Gas permeable film
- ▶ Reusable sampling valve for in-process testing
- ▶ Tubing for sterile weld connections
- ▶ Scalable, user friendly design

Biocompatibility Tests	Result	Test Protocol
USP Class VI	Pass	USP <88>
Toxicity	Nontoxic	USP <87>
Heavy metals	<2 ppm	ISO 3826-1
Buffering capacity	1.22 mL	USP <661>
Non-volatile residue	8.6 mg	USP <661>
Residue on ignition (polyolefins)	<1 mg	ISO 3826-1
Acidity and alkalinity	Pass	ISO 3826-1
Oxidizable constituents	<1.5 mL	ISO 3826-1
Absorbance	<0.2 abs unit	ISO 3826-1
Reducing substances	0.34 mL	EP 3.1.14
Local effects after implantation	Pass	ISO 10993-6
Irritation and delayed-type sensitivity	Pass	ISO 10993-10
Systemic toxicity	Pass	ISO 10993-11

Physical Properties	Result	Test Protocol
O ₂ transmission (cm ³ /100 in ² /24 hrs) at (25°C; 0% RH)	153	ASTM D-3985
CO ₂ transmission (cm ³ /100 in ² /24 hrs) at (25°C; 0% RH)	1183	MOCON Test Method
Moisture vapor transmission (g/100 in ² /24 hrs)	0.94	ASTM D-1249
Transmittance (%)	83	ASTM D-1003
Tensile strength (psi)	3400/3700	ASTM D-638
Elastic modulus (E)	540/480	ASTM D-638

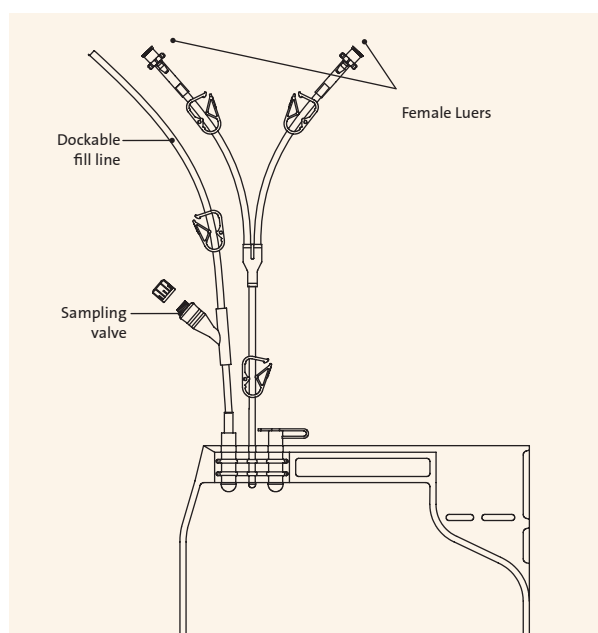

Cat. No.	Size	Fill Volume	Qty/Pk
91-200-84	500 mL	190 mL	1
91-200-85	1L	381 mL	1
91-200-86	3 L	633 mL	1
91-200-87	5L	1252 mL	1

CRYOPRESERVATION BAGS

Cryopreservation bags are designed for storage, preservation, and transfer of cells.

Design Offers

- ▶ Unique bag film material remains flexible at low temperatures (-196°C).
- ▶ Proprietary membrane port design offers thinner walls for increased flexibility and attached cap minimizes membrane exposure during freezing.
- ▶ Industry standard label pocket design offers ease-of-use and traceability in labeling.

Features and Benefits

- ▶ Polyolefin film – Proprietary EVA blend specifically selected for its low temperature properties while maintaining flexibility and clarity when filled with liquid.
- ▶ Membrane port – The attached cap snaps into place to protect the contents and minimizes membrane exposure during use.
- ▶ Label pocket – Supports use of computer-generated labels; product information can be viewed quickly by simply opening the freezing cassette
- ▶ Integral fill tube – The unique manufacturing method used to secure the fill tube to the container body eliminates the need for PVC interfaces with the liquid nitrogen storage section of the container.
- ▶ Interface/Connectors – Compatible with sterile connection technology and smart seal technology (Sebra® Model 1100 tube welder); fits in a variety of freezing cassette systems.

Physical Integrity

The physical integrity of the containers were evaluated for their ability to withstand temperature variations experienced during routine storage of hematopoietic progenitor cell products. All containers passed the physical integrity tests performed, which included initial pressure, leak, microbial challenge, and dye immersion tests.

Cell Quality

Cell quality was assessed on our cryogenic storage containers using diluted HPC with 10% DMSO. All containers met the acceptance requirement for MNC and CD34+ cell recovery of $\geq 70\%$ relative to cell counts of the sample prior to cryopreservation. The average MNC and CD34+ cell recoveries were 81% and 84%, respectively. All containers met ≥ 1 CFU acceptance criteria with an average of 78% recovery.

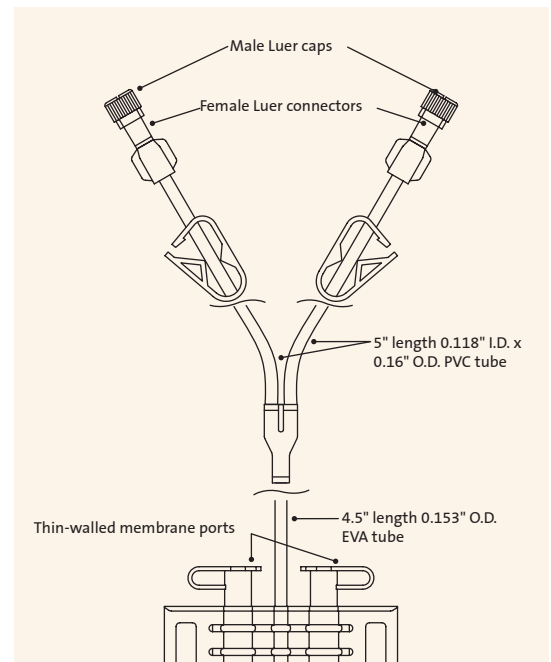

Cat. No.	Size	Fill Volume	Qty/Pk
91-200-88	50 mL	10 - 20 mL	1
91-200-89	250 mL	30 - 70 mL	1
91-200-90	500 mL	55 - 100 mL	1
91-200-91	750 mL	80 - 190 mL	1

ROCKER CELL CULTURE BAGS

Rocker cell culture bags are designed for use with commercial rocking-motion bioreactor chambers. They feature ethylene vinyl acetate/ultra-low density polyethylene (ULDPE) 9101 film and stability bars on each side. These sterile, single-use cell culture bags are ideal for applications from basic research to large-scale biopharmaceutical manufacturing.

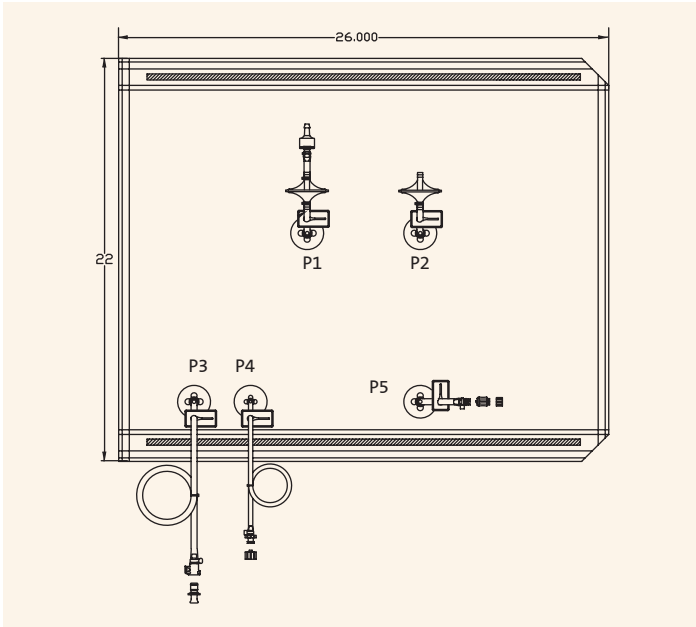

Cat. No.	Size	Qty/Pk
91-200-78	20L	1
	Check valve with 1/4" barb	
P1	PVDF 8004022 filter 2" length 3/16" I.D. x 3/8" O.D. PCMGS tube	
P2	PVDF 8004022 filter 2" length 3/16" I.D. x 3/8" O.D. PCMGS tube	
P3	Female MPC connector with 1/4" barb Male MPC plug 40" length 1/4" I.D. x 7/16" O.D. chemically resistant, heat sealable flexible tube	
P4	Female Luer with 1/4" barb Male Luer plug 40" length 1/8" I.D. x 1/4" O.D. chemically resistant, heat sealable flexible tube	
P5	Female Luer with 1/4" barb Swabbable valve Male Luer plug without stem	

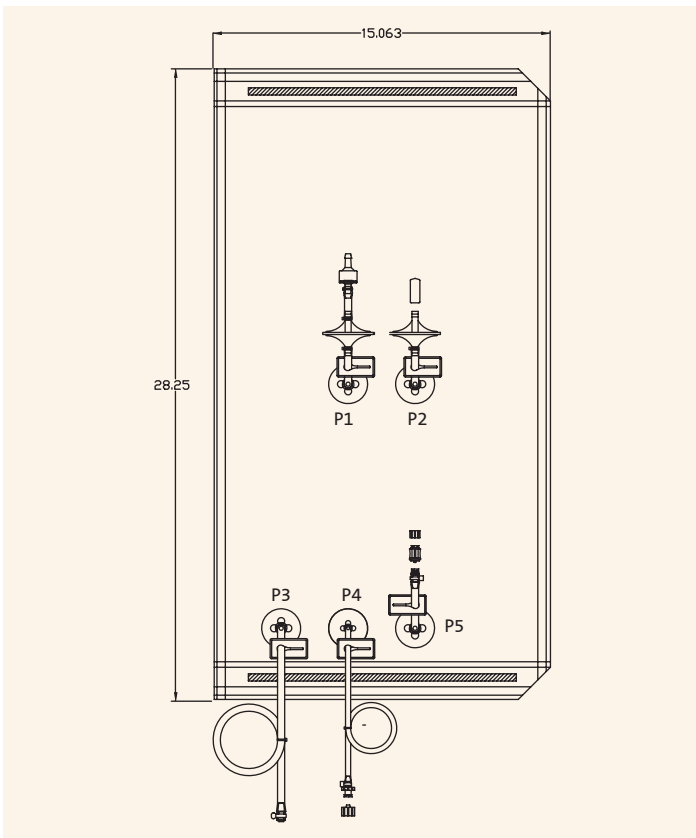

Cat. No.	Size	Qty/Pk
91-200-92	22L	1
	Check valve with 1/4" barb	
P1	PVDF 8004022 filter 2" length 3/16" I.D. x 3/8" O.D. PCMGS tube	
P2	PVDF 8004022 filter 2" length 3/16" I.D. x 3/8" O.D. PCMGS tube	
P3	Plug with 1/4" barb 48" length 1/4" I.D. x 7/16" O.D. chemically resistant, heat sealable flexible tube	
P4	Female Luer with 1/4" barb Male Luer plug 48" length 1/8" I.D. x 1/4" O.D. chemically resistant, heat sealable flexible tube	
P5	Female Luer with 1/4" barb Swabbable valve Male Luer plug without stem	

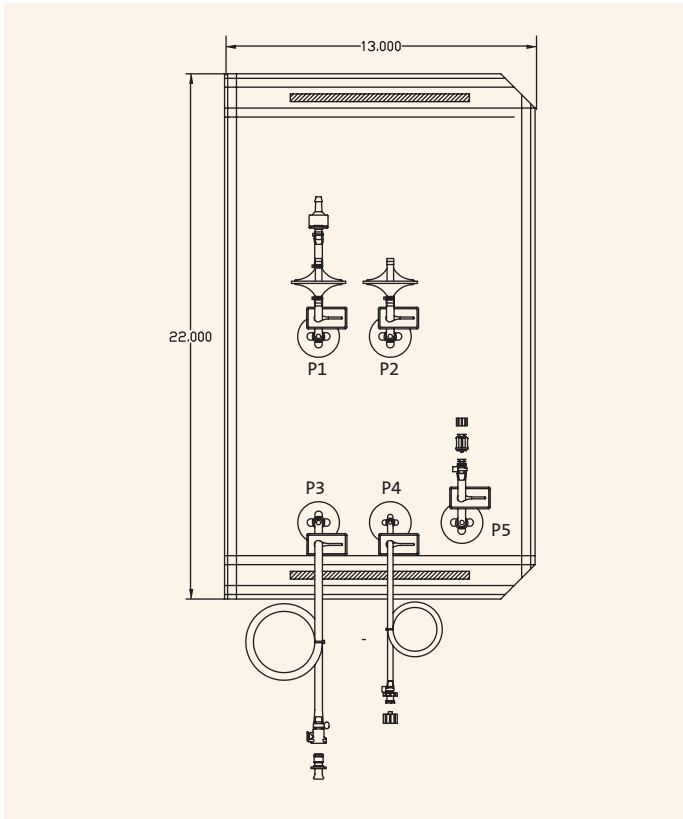

Cat. No.	Size	Qty/Pk
91-200-79	10L	1
	Check valve with 1/4" barb	
P1	PVDF 8004022 filter 2" length 3/16" I.D. x 3/8" O.D. PCMG tube	
P2	PVDF 8004022 filter 2" length 3/16" I.D. x 3/8" O.D. PCMG tube	
P3	Female MPC connector with 1/4" barb and plug 40" length 1/4" I.D. x 7/16" O.D. chemically resistant, heat sealable flexible tube	
P4	Female Luer with 1/4" barb and plug 40" length 1/8" I.D. x 1/4" O.D. chemically resistant, heat sealable flexible tube	
P5	Female Luer with 1/4" barb Swabbable valve Male Luer plug without stem	

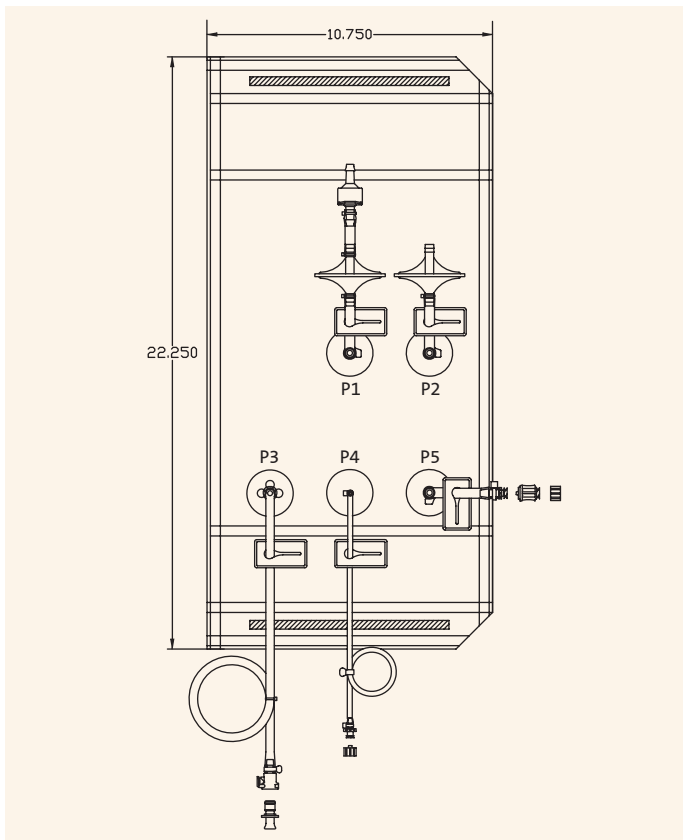

Cat. No.	Size	Qty/Pk
91-200-80	2L	1
	Check valve with 1/4" barb	
P1	PVDF 8004022 filter 2" length 3/16" I.D. x 3/8" O.D. PCMG tube	
P2	PVDF 8004022 filter 2" length 3/16" I.D. x 3/8" O.D. PCMG tube	
P3	Female MPC connector with 1/4" barb Male MPC plug 40" length 1/4" I.D. x 7/16" O.D. chemically resistant, heat sealable flexible tube	
P4	Female Luer with 1/4" barb Male Luer plug 40" length 1/8" I.D. x 1/4" O.D. chemically resistant, heat sealable flexible tube	
P5	Female Luer with 1/4" barb Swabbable valve Male Luer plug without stem	

ROCKER CELL CULTURE BAGS (CONTINUED)

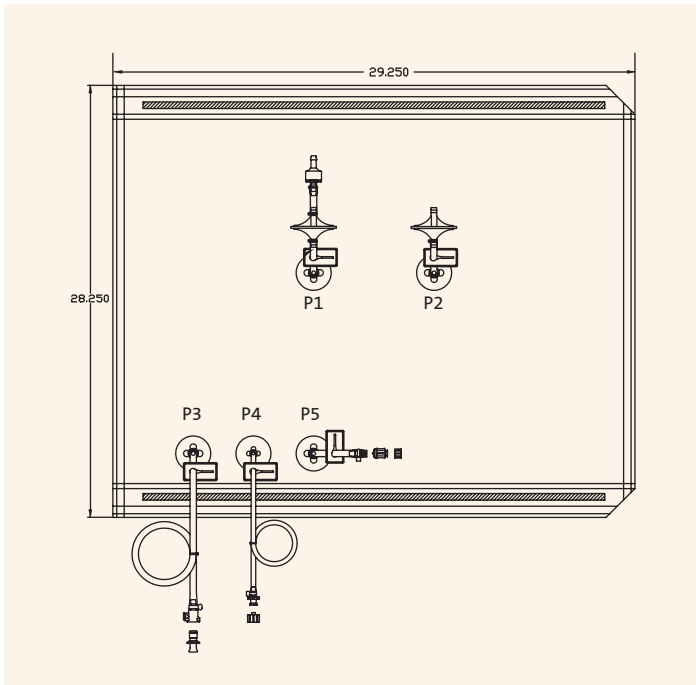

Cat. No.	Size	Qty/Pk
91-200-81	50L	1
P1	Check valve with 1/4" barb PVDF 8004022 filter 2" length 3/16" I.D. x 3/8" O.D. PCMGS tube	
P2	PVDF 8004022 filter 2" length 3/16" I.D. x 3/8" O.D. PCMGS tube	
P3	Female MPC connector with 1/4" barb Male MPC plug 40" length 1/4" I.D. x 7/16" O.D. chemically resistant, heat sealable flexible tubing	
P4	Female Luer with 1/4" barb Male Luer plug 40" length 1/8" I.D. x 1/4" O.D. chemically resistant, heat sealable flexible tubing	
P5	Female Luer with 1/4" barb Swabbable valve Male Luer plug without stem	

TUBING SETS

Optional tubing sets are available in combination with all single-use bag options.

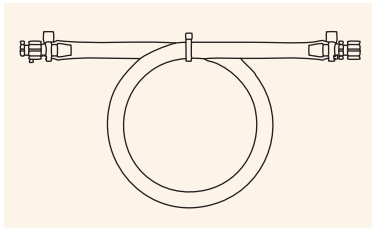

Cat. No.	Description	Qty/Pk
91-700-00	36" length 1/4" I.D. clear, chemically resistant, heat sealable, flexible tubing Male Luer and female Luer cap Female Luer and male Luer cap	1

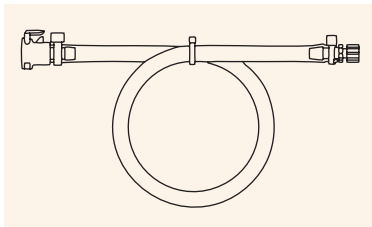

Cat. No.	Description	Qty/Pk
91-700-04	36" length 1/4" I.D. clear, chemically resistant, heat sealable, flexible tubing Female MPC connector Female Luer and male Luer cap	1

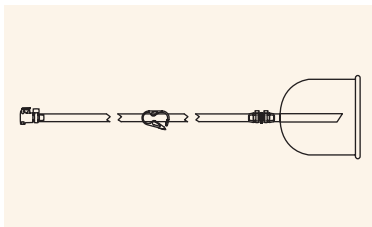

Cat. No.	Description	Qty/Pk
91-700-12	24" length 1/4" I.D. clear, chemically resistant, heat sealable, flexible tubing Female MPC connector with 1/4" barb Pinch clamp Filling bell	1

SINGLE-USE BAGS FOR CORNING® HYPERSTACK® VESSELS

These single-use bags can be connected to tubing by tube welding or by using the pre-assembled multipurpose connectors. They can be used to add media, trypsin, or quenching substrates to culture cells in an entirely closed environment.

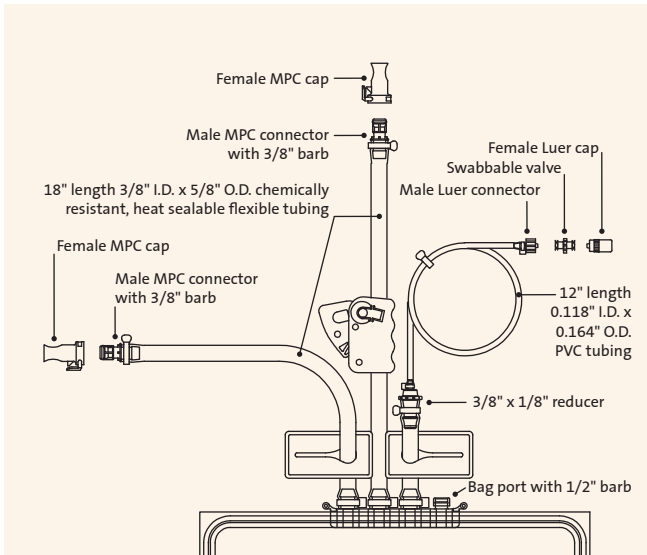

Cat. No.	Description	Film Type	Size	Qty/Pk
91-200-75	Trypsin bag	ULDPE	5L	1

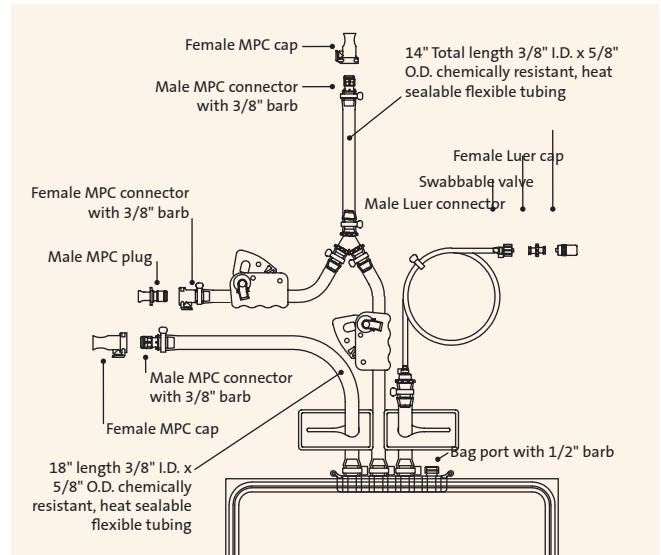

Cat. No.	Description	Film Type	Size	Qty/Pk
91-200-76	Quench bag	ULDPE	5L	1

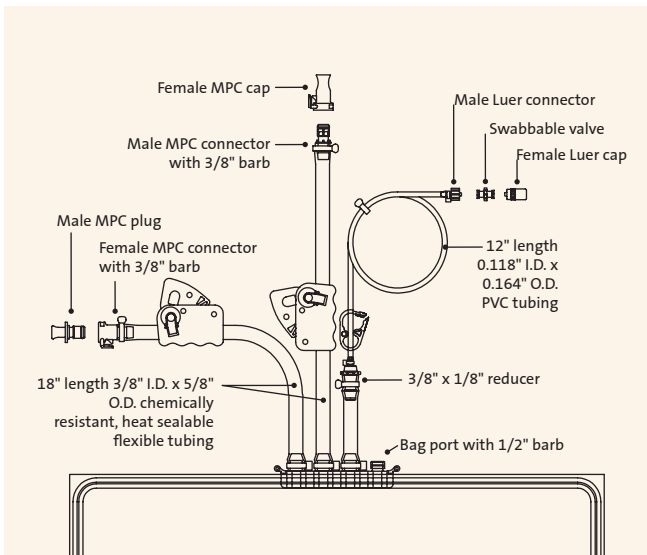

Cat. No.	Description	Film Type	Size	Qty/Pk
91-200-77	Media bag	ULDPE	20L	1

TANK LINERS

Corning's portfolio of sterile tank liners are designed to fit cylindrical tanks. Tank liners are manufactured with ultra-low density polyethylene (ULDPE) and are available in a range of sizes.

Features and Benefits

- ▶ Sterile, individually packaged
- ▶ Animal-free components
- ▶ Reduce costs associated with the cleaning and validation of tanks
- ▶ Reduce labor costs and increase turnaround time
- ▶ Reduce the risks associated with cross-contamination
- ▶ Help extend the life of reusable tanks, resulting in lower capital expenditures
- ▶ Wide variety of sizes

Gusseted Tank Liners (3D)

Cat. No.	Max. Volume	Diameter	Approx. Depth	Qty
91-300-15	50L	13"	27"	1
91-300-25	100L	18"	30"	1
91-300-35	200L	22"	36"	1

Non-gusseted Tank Liners (2D)

Cat. No.	Max. Volume	Diameter	Approx. Depth	Qty
91-300-20	130L	18"	30"	1
91-300-30	200L	22.5"	36"	1
91-300-80	1090L	42"	49"	1

Ethyl Vinyl Acetate (EVA) Film

12.5 mil co-extrusion film — Collection bags.

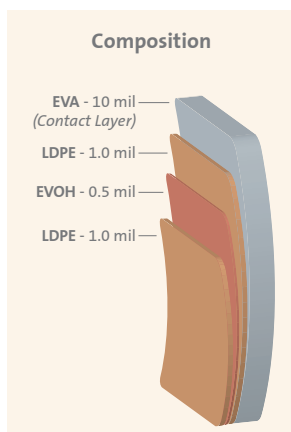

Biocompatibility Tests	Result	Test Protocol
USP intracutaneous reactivity test	Pass	USP <88>
USP acute systemic injection test	Pass	USP <88>
USP intramuscular implantation test	Pass	USP <88>
Toxicity	Nontoxic	USP <87>
Hemolysis	Non-hemolytic	ISO 10993-4
Bacterial endotoxin	<0.015 EU/mL	USP <85>
Physical Properties	Result	Test Protocol
H ₂ O transmission (g/100 in ² /24 hrs)	0.011	ASTM F-1249
CO ₂ transmission (cm ³ /100 in ² /24 hrs)	0.58	MOCON Test Method
O ₂ transmission (cm ³ /100 in ² /24 hrs)	0.28	ASTM F-3985
Ultimate tensile	3100 psi	ASTM D-638
Ultimate elongation	>650%	ASTM D-638
100% modulus	1000 psi	ASTM D-638
Tear strength	550 lbs/in	ASTM D-1004
Low pressure brittleness	>-75°F	ASTM D-1290
Puncture resistance	22.4 lbs	FTMS 101 B

Metallocene Film

9.0 mil co-extruded blend of cross-linked polyethylene, EVOH, and Nylon — Collection bags.

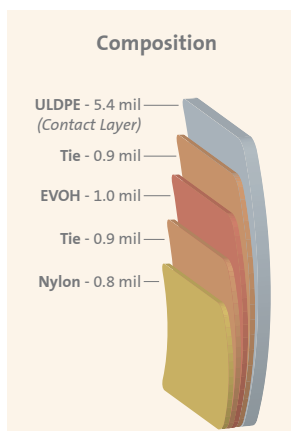

Biocompatibility Tests	Result	Test Protocol
Toxicity	Nontoxic	USP <87>
Bacterial endotoxin	<0.005 EU/mL	USP <85>
Hemolysis	Non-hemolytic	ISO 10993-4
Heavy metals	<1 ppm	ISO 3826-1; USP <661>
Buffering capacity	<1 mL	USP <661>
Non-volatile residue	<1 mg	USP <661>
Residue on ignition	<1 mg	ISO 3826-1; USP <661>
Appearance	Pass	--
Acidity and alkalinity	Pass	--
Absorbance	0.04 units	--
Oxidizable substance	<0.1 mL	--
Transparency	Pass	--
Physical Properties	Result	Test Protocol
H ₂ O transmission (g/m ² /24 hrs 23°C, 100% RH)	0.455	ASTM F-1249
CO ₂ transmission (cm ³ /m ² /24 hrs 23°C, 50% RH outside)	<1.0	ASTM F-2476
O ₂ transmission rate (cm ³ /m ² /24 hrs 23°C, 100% RH inside and 50% RH outside)	0.148	ASTM F-1927
Ultimate tensile strength	3094 psi	ASTM D-638
Elongation	416 (%)	ASTM D-638
Yield strength	1972 psi	--
Seam strength	18 pounds	--
Temperature range	-80°C to 60°C	--
Sterility Assurance Level	SAL 10 ⁻⁶	--

Ultra-Low Density Polyethylene (ULDPE)/Ethylene Vinyl Acetate (EVA) Film

Single-ply multilayer structure with inert PE fluid contact layer.
Film is animal-free—Rocker cell culture bags.

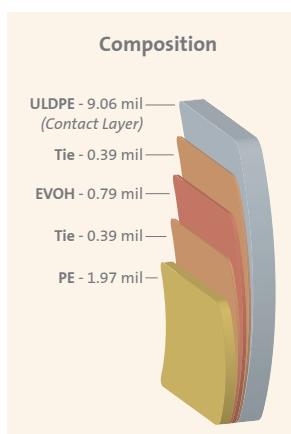

Physical Properties	Result	Test Protocol
Haze (%)	5	ASTM D-1003
Clarity (%)	98	ASTM D-1003
Transmittance (%)	93	ASTM D-1003
Tensile strength at break (Mpa)	14	ASTM D-882
Elongation at break (%)	280	ASTM D-882
Elastic modulus (Mpa)	370	ASTM D-882
Break at cold temperature (°C)	below -45°C	ISO 8570
Density (g/cm ³)	0.9	ASTM D-792
H ₂ O transmission rate g/m ² /24 hrs	0.4 (23°C)	ASTM F-1249
O ₂ permeability cm ³ /m ² /24 hrs	0.1 (23°C, 0% RH)	ASTM D-3985
CO ₂ permeability cm ³ /m ² /24 hrs	<0.2 (23°C, 0% RH)	MOCON Permatran C-IV

Ultra-Low Density Polyethylene (ULDPE) Film

Fluid contact layer is 5.0 mil, ultra-low density polyethylene. Outer film is 5-layer, 7 mil co-extrusion film—Bags for Corning® HYPERStack® vessels, collection bags.

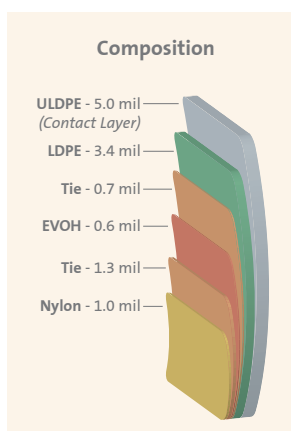

Biocompatibility Tests	Result	Test Protocol
USP intracutaneous reactivity test	Pass	USP <88>
USP acute systemic injection test	Pass	USP <88>
USP intramuscular implantation test	Pass	USP <88>
USP MEM elution method	Nontoxic	USP <87>
Physiochemical test for plastics	Pass	USP <661>

Physical Properties	Result	Test Protocol
H ₂ O transmission (g/100 in ² /24 hrs)	0.017	ASTM F-1249
CO ₂ transmission (cm ³ /100 in ² /24 hrs)	0.129	ASTM F-2476
O ₂ transmission (cm ³ /100 in ² /24 hrs)	0.043	ASTM F-1927

	Average Force	Average MOE	Average Elongation	Test Protocol
Tensile strength	32.73 lbs	25110 psi	1080%	ASTM D 882-02

	Min Force	Average Force	Max Force	Test Protocol
Tear resistance	6.77 lbs	7.21 lbs	7.74 lbs	ASTM D1004-07
Puncture resistance	16.42 lbs	18.61 lbs	19.51 lbs	FTMS 101C

Polyolefin (PO) Film

Single-web, 12 mil polyolefin monolayer designed for extremely low temperatures— Cell expansion bags.

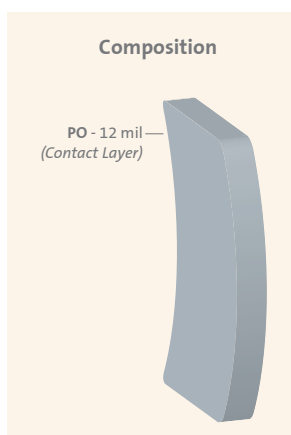

Biocompatibility Tests	Result	Test Protocol
USP Class VI	Pass	USP <88>
Toxicity	Nontoxic	USP <87>
Hemolysis	Non-hemolytic	ISO 10993-4
Heavy metals	Pass	ISO 3826-1; USP <661>
Buffering capacity	Pass	USP <661>
Non-volatile residue	Pass	USP <661>
Residue on ignition	Pass	ISO 3826-1; USP <661>
Local effects after implantation	Pass	ISO 10993-6
Irritation and delayed-type sensitivity	Pass	ISO 10993-10
Systemic toxicity	Pass	ISO 10993-11
Bacterial endotoxin	<20 EU/device	USP <85>

Physical Properties	Result	Test Protocol
H ₂ O transmission g/100 in ² /24 hrs at 25°C	1.1	ASTM F1249
CO ₂ transmission cm ³ /100 in ² /24 hrs at 25°C, 0% RH	1477	ASTM F2476
O ₂ transmission cm ³ /100 in ² /24 hrs at 25°C, 0% RH	180	ASTM D3985
Tensile strength (Mpa)	17	ASTM D882
Elongation at break, MD/TD (%)	560/700	ASTM D882
Elastic modulus (Mpa)	17	ASTM D882
Break at cold temperature (°C)	Below -80°C	ISO 8570
Glass transition temperature (Tg)	-48°C	DSC
Density (g/cm ³)	0.92	ASTM D792
Low temperature, (remains flexible)	-196°C	--

Tank Liner Film

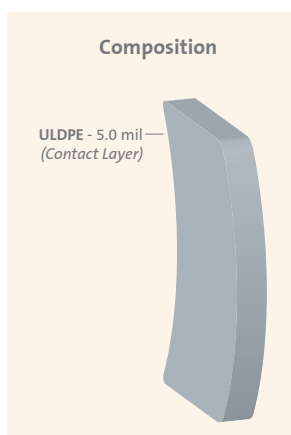

Biocompatibility Tests	Result	Test Protocol
USP intracutaneous reactivity	Pass	USP <88>
USP acute systemic injection	Pass	USP <88>
USP intramuscular implantation	Pass	USP <88>
Toxicity	Nontoxic	USP <87>
Physiochemical test for plastics	Pass	USP <661>

Physical Properties	Result	Test Protocol
H ₂ O transmission (g/100 in ² /24 hrs)	0.017	ASTM F-1249
CO ₂ transmission (cm ³ /100 in ² /24 hrs)	0.129	ASTM F-2476
O ₂ transmission (cm ³ /100 in ² /24 hrs)	0.043	ASTM F-1927

	Average MOE	Average Elongation	Test Protocol
Tensile strength	5756 psi	710%	ASTM D 882
	Average Force		
Impact strength	2.52 lbs	7.74 lbs	ASTM D 1709

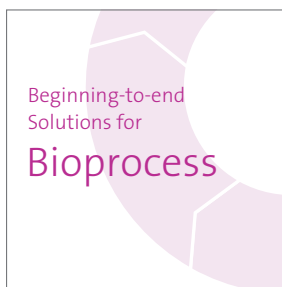

www.corning.com/lifesciences/solutions

Corning is built upon a foundation of innovation and manufacturing excellence. Over the past 160 years, we have strived to offer the highest quality products to ensure reproducibility and reliability in your daily operations. While our experience is undeniable, our expertise in product applications completes the spectrum of support we offer.

Corning single-use adhesion and suspension cell culture products enable scale-up in bioprocess manufacturing. From cell line development and process development to GMP manufacturing, our vessels provide the necessary platform to accomplish your goals. Supporting products such as closed system solutions, media, and advanced surfaces round out the product offering, providing a complete solution.

For more specific information on claims, visit the Certificates page at www.corning.com/lifesciences.

Warranty/Disclaimer: Unless otherwise specified, all products are for research use only. Not intended for use in diagnostic or therapeutic procedures. Not for use in humans. Corning single-use containers are not intended for use in parenteral applications. Corning Life Sciences makes no claims regarding the performance of these products for clinical or diagnostic applications

For additional product or technical information, visit www.corning.com/lifesciences or call 800.492.1110. Customers outside the United States, call +1.978.442.2200 or contact your local Corning sales office.

Corning Incorporated
Life Sciences

836 North St.
Building 300, Suite 3401
Tewksbury, MA 01876
t 800.492.1110
t 978.442.2200
f 978.442.2476
www.corning.com/lifesciences

Worldwide
Support Offices

ASIA/PACIFIC
Australia/New Zealand
t 61 427286832
China
t 86 21 3338 4338
f 86 21 3338 4300
India
t 91 124 4604000
f 91 124 4604099

Japan
t 81 3-3586 1996
f 81 3-3586 1291

Korea
t 82 2-796-9500
f 82 2-796-9300
Singapore
t 65 6572-9740
f 65 6861-2913

Taiwan
t 886 2-2716-0338
f 886 2-2516-7500

EUROPE

France
t 0800 916 882
f 0800 918 636

Germany
t 0800 101 1153
f 0800 101 2427

The Netherlands
t 31 20 655 79 28
f 31 20 659 76 73

United Kingdom
t 0800 376 8660
f 0800 279 1117

All Other European
Countries

t 31 (0) 20 659 60 51
f 31 (0) 20 659 76 73

LATIN AMERICA
grupoLA@corning.com

Brasil
t (55-11) 3089-7400

Mexico
t (52-81) 8158-8400

CORNING | **FALCON** | **AXYGEN** | **GOSELIN** | **PYREX**

For a listing of trademarks, visit www.corning.com/clstrademarks. All other trademarks are the property of their respective owners.