On Road Durability and Field Experience Obtained with an Aluminum Titanate Diesel Particulate Filter

Dominik Rose, Otto A. Pittner, Claudia Jaskula and Thorsten Boger
Corning GmbH

Thomas Glasson and Victor Miranda Da Costa
Corning S.A.S.

Reprinted From: **Diesel Exhaust Emission Control, 2007
(SP-2080)**

ISBN 0-7680-1635-5



9 780768 016352

SAE *International*[™]

**2007 World Congress
Detroit, Michigan
April 16-19, 2007**

By mandate of the Engineering Meetings Board, this paper has been approved for SAE publication upon completion of a peer review process by a minimum of three (3) industry experts under the supervision of the session organizer.

All rights reserved. No part of this publication may be reproduced, stored in a retrieval system, or transmitted, in any form or by any means, electronic, mechanical, photocopying, recording, or otherwise, without the prior written permission of SAE.

For permission and licensing requests contact:

SAE Permissions
400 Commonwealth Drive
Warrendale, PA 15096-0001-USA
Email: permissions@sae.org
Fax: 724-776-3036
Tel: 724-772-4028



For multiple print copies contact:

SAE Customer Service
Tel: 877-606-7323 (inside USA and Canada)
Tel: 724-776-4970 (outside USA)
Fax: 724-776-0790
Email: CustomerService@sae.org

ISSN 0148-7191

Copyright © 2007 SAE International

Positions and opinions advanced in this paper are those of the author(s) and not necessarily those of SAE. The author is solely responsible for the content of the paper. A process is available by which discussions will be printed with the paper if it is published in SAE Transactions.

Persons wishing to submit papers to be considered for presentation or publication by SAE should send the manuscript or a 300 word abstract of a proposed manuscript to: Secretary, Engineering Meetings Board, SAE.

Printed in USA

On Road Durability and Field Experience Obtained with an Aluminum Titanate Diesel Particulate Filter

Dominik Rose, Otto A. Pittner, Claudia Jaskula and Thorsten Boger

Corning GmbH

Thomas Glasson and Victor Miranda Da Costa

Corning S.A.S.

Copyright © 2007 SAE International

ABSTRACT

A novel diesel particulate filter for passenger car applications was introduced by Corning, based on a stabilized aluminum titanate composition. As part of the development and material evaluation Corning has performed extensive on-road testing of the new material. The testing included several vehicles, filters, system layouts and driving profiles. The filters were tested from 100,000 km to 240,000km. All test vehicles were equipped with instrumentation and data acquisition hardware, enabling the detailed recording of the relevant parameters such as temperature profiles inside the filter, the pressure drop as well as engine data. Throughout the field evaluations the filters were regularly checked for emissions over the NEDC on a chassis dynamometer according to the current European test protocol. In all cases excellent emission performance has been observed over the duration of the tests. The pressure drop performance has generally been good. After the on-road testing all filters have been analyzed following a detailed protocol. No negative material changes or changes in the thermo-mechanical properties have been observed. Some information about the accumulation of ash has been obtained through CT scans. Details of the tests and the results obtained are discussed in this manuscript.

INTRODUCTION

In Europe the share of diesel engine passenger cars is continuously increasing. This is partially attributed to their superior fuel economy as well as their excellent driving characteristics ("fun to drive" factor), due to the impressive progress made in diesel engine technology. Environmental concerns due to the particulate emissions of diesel engines combined with the now available knowledge on the significant health impact of small soot particles are expected to result in a significant tightening of the European particulate matter emission legislation for passenger cars. The European Commission proposal is to change the limit of particulate matter emissions from

25mg/km (Euro 4) to 5mg/km (Euro 5). These low particulate emissions levels and the removal of ultrafine particles (<100 nm), those of greatest health concern, can only be achieved through the use of highly efficient wall-flow diesel particulate filters.

The original introduction of SiC filters was based on bare filters and a fuel additive. The new generations of particulate filter systems for passenger car applications are based on catalyzed filters and therefore have special requirements on the filter media to facilitate the catalyst coating, without having negative impact on pressure drop, filter system durability and catalyst effectiveness.

In 2005 Ogunwumi et al. [1] reported on a new material based on a stabilized aluminum titanate composition for application as diesel particulate filter. First engine bench and vehicle test data obtained with this new filter material were presented by Boger et al. [2] and Heibel et al. [3], demonstrating the excellent filtration performance, low pressure drop characteristics and high thermal durability. The new aluminum titanate material, marketed as DuraTrap® AT, found its first commercial application in Volkswagen's unique diesel aftertreatment system applied to the Golf Class vehicles with the 1.9 and 2.0 TDI engines [4].

As part of the development of the new aluminum titanate filter product Corning has performed significant vehicle durability testing to evaluate its robustness and reliability under real driving conditions. Since the start of the activities a fleet of six test vehicles has been involved in this test program, and more than 1 million kilometers have been accumulated. The filters were tested under different test protocols, including extended city driving as well as mixed cycles. With the different filters involved different mileages were accumulated; two filters having been tested over 240,000km. This mileage target is currently viewed as the practical lifetime of a European passenger car vehicle.

In this paper we report the first durability results with the new aluminum titanate filter material obtained during this fleet evaluation.

EXPERIMENTAL

TEST VEHICLES AND FILTERS

The durability evaluation has been performed in Germany on six test vehicles, all with modern 4 cylinder diesel engines, certified according to the Euro 4 standards. Details about the test vehicles are given in Table 1.

Table 1. Test Vehicles

Vehicle	Engine			Vehicle Weight
	Displacement	FIS	Rated Power	
A	2148 cm ³	CR	110 kW	1640 kg
B	2148 cm ³	CR	110 kW	1540 kg
C	1896 cm ³	PUI	74 kW	1573 kg
D	1896 cm ³	PUI	74 kW	1573 kg
E	1968 cm ³	PUI	103 kW	1529 kg
F	1968 cm ³	PUI	103 kW	1540 kg

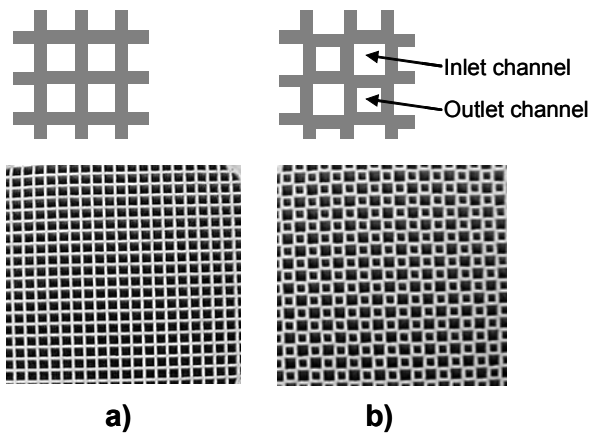

Figure 1. Photo and schematics of the two cell designs included in the durability study. (a) Standard, symmetric cell geometry; (b) Asymmetric Cell Technology (ACT). Note: unplugged cross-sections of the filters are shown.

The vehicles were equipped with different exhaust aftertreatment systems, all being located in a close-coupled position directly after the turbo charger. Two vehicles (A and B) had systems comprising an oxidation catalyst (DOC) followed by the catalyzed soot filter (CSF). The other vehicles (C – F) utilized catalyzed filters of different size, cell geometry and shape, which provided the entire oxidation functionality, as described for example in reference [4]. This type of system, in which the filter provides not only the filter function but also the entire oxidation functionality, will be called DOCSF throughout this paper. The aluminum titanate filters are available in two different cell designs, shown in Figure 1. One has the

standard configuration, known from catalytic converters with all channels being of the same size and of square shape (Fig. 1a). The other cell configuration, shown in Figure 1b, is called Asymmetric Cell Technology (ACT) and provides for an enlarged inlet channel volume for extended ash accumulation. Details about this advanced cell design have been discussed in [2-6].

In Table 2, information is given about the different filters that have been tested. All filters included in the test program had a cell density of 300cps and 0.013 inch wall thickness. Filters 1-7 were cylindrical with a diameter of 5.66" and a length of 6", whereas filter 8 and 9 had an oval cross-section, as used in the Volkswagen series application [4]. Filters 1-3 were catalyzed with a medium washcoat and catalyst loading in the DOC + CSF application of vehicle A and B. Filters 4-9 were all tested in the DOCSF application and had relatively high washcoat and catalyst loadings. Catalyst coatings were supplied by two different catalyzers.

Table 2. Filters used in the test program (all filters had a 300cps / 13 mil wall thickness cell density).

Filter	Volume	Shape	Cell Design	Catalyst Loading
#1	2.47 liter	Round	Standard	Medium
#2, #3	2.47 liter	Round	ACT	Medium
#4, #5, #6	2.47 liter	Round	Standard	High
#7	2.47 liter	Round	ACT	High
#8, #9	3.0 liter	Oval	ACT	High

It is worth mentioning that whereas filters 1-3 and 8-9 were used with production type cannings, filters 4-7 were canned using a simple prototype system derived from an oxidation catalyst design. The latter canning was found to provide only limited durability in the close coupled application and failed for filters 4, 5 and 7 after 100,000-120,000km with severe damages at the welding joint between inlet pipe to the inlet cone.

INSTRUMENTATION AND DATA ACQUISITION

All vehicles were equipped with a data acquisition system (IAV DriveRecorder) for the durability tests. A number of relevant engine and control parameters were obtained from the ECU via the CAN bus and continuously monitored with a frequency of 1Hz. In addition to the ECU parameters, in some cases additional lambda sensors were installed to monitor the oxygen content in the exhaust up and downstream of the filter. The pressure drop across the filter was obtained from the vehicle differential pressure sensor, with the values being obtained from the CAN bus. All filters were equipped with 6 to 14 thermocouples (Type K, 0.8mm diameter) to be able to collect information about the temperatures and temperature gradients inside the filter, especially during filter regenerations. Special care was taken during the installation of the thermocouples to

avoid early thermocouple breakage due to the harsh operating environment during vehicle operation. A sketch of a typical setup (example shown for vehicle A) is shown in Figure 2. A photo and sketch of a filter instrumented with 14 thermocouples (filter 9) is shown in Figure 3.

An example of the thermocouple arrangement is shown in Figure 3. The distribution with a larger number of thermocouples in the rear was done to ensure that the peak temperatures, usually observed in the rear of the filter, as well as the highest temperature gradients, usually observed close to the skin of the filter, can be determined. Similar thermocouple layouts have been used in extensive engine bench testing programs, allowing a direct comparison of the data obtained on the test vehicles. It is important to note that the determination of the maximum radial gradients is done by placing the outermost thermocouples as close to the skin as possible, i.e. into the last one or two channels before the skin. We generally used a spacing of 10mm between the two outermost thermocouples to obtain temperature gradient data that can be compared between different test setups and results obtained during engine test programs.

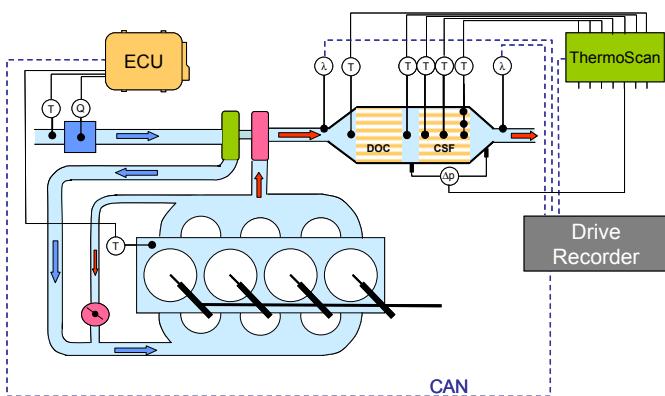

Figure 2. Typical setup as used in the durability tests (example for vehicle A).

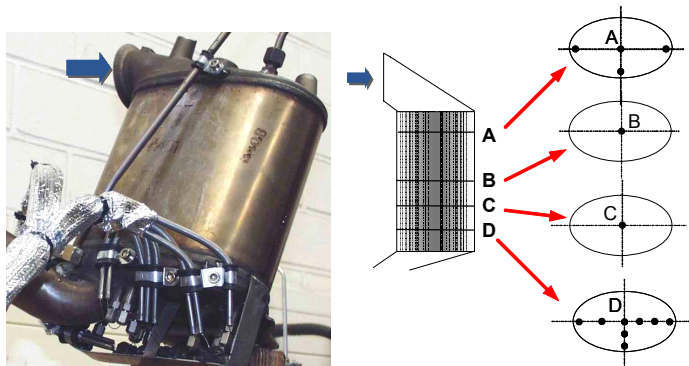

Figure 3. Photo and sketch of thermocouple locations of filter 9. The blue arrows indicate the exhaust flow inlet.

VEHICLE OPERATION

All vehicle testing was conducted in Germany. The vehicles were operated under different duty-cycles to obtain performance information under a wide range of practical driving patterns.

Extended city driving over several thousand kilometers is viewed as the most extreme test condition for diesel particulate filter applications. Characteristic of this driving mode is that the engine out conditions essentially do not allow for passive regeneration (e.g. high soot loads are observed) and the operation is highly transient with significant operation in idle at low flow rates (e.g. difficult conditions for active regenerations with a minimum of convective heat removal). All city driving tests were performed in the Wiesbaden/Mainz area. The average vehicle velocity during these tests was 20-25km/h. The maximum vehicle speed was 50km/h and the maximum engine speed was constrained in our entire program to 3000 min⁻¹.

Extra-urban and highway driving is viewed as a less demanding driving profile since the exhaust temperatures generally allow for more passive regeneration and the exhaust flow rates are also higher, enabling better regeneration performance. Nevertheless, these profiles also create some characteristic challenges for the active filter regeneration, such as engine over run conditions with oxygen rich exhaust flow (e.g. vehicle approaching a traffic jam on a highway) or rapid changes in engine speed to idle, approaching exits or stops at gas stations. With the exception of vehicle A, which was aimed at representing a typical German commuting and medium distance travel profile, we have generally restricted the maximum vehicle and engine speed on highway driving to 100-130km/h and 3000min⁻¹, respectively. For extra urban driving the legal limit is 100km/h and we have again restricted the engine speed to 3000 min⁻¹. The objective of these restrictions was to limit the extent of passive regeneration and ensure severe conditions with significant amounts of soot on the filter during the active regenerations. The vehicle speed limit is representative of most European countries having speed limits in the range of 110-130km/h.

For extended durability testing we have applied a mixed cycle, which was designed to represent a "typical" operating profile for a European passenger car. The mixed cycle consists of a continuous repetition of a block of 40km highway followed by 40km in city, 40km highway, and 120km extra urban driving. The restrictions mentioned above apply to each part of the cycle.

In Figure 4 an example of a typical driving profile in our mixed cycle is shown. As the same rules applied also in the dedicated city, extra urban and highway profiles, the respective sections in Figure 4 are also representative for them.

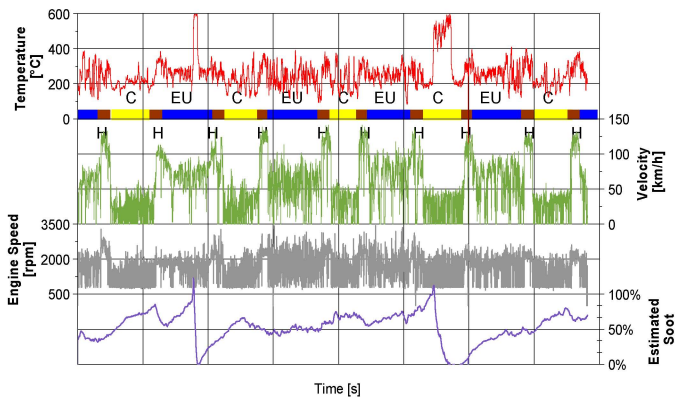

Figure 4. Example of a typical driving profile during our mixed cycle operation. The color bars/letters indicate the different driving profiles: yellow (C) = city, blue (EU) = extra urban, brown (H) = highway.

The relatively low exhaust temperatures of our constrained operating profile can be seen in Figure 4 as well as the two regeneration events, which occurred. The curve at the bottom shows a relative value of the estimated soot mass. The profile is quite typical of rapid accumulation during the city operation and phases during which the soot collected and the soot that is continuously oxidized are essentially in equilibrium (e.g. a stable soot load). The effect of the active regenerations can also be clearly seen. In Figure 5 a typical example of an operation in an extended city cycle is shown. The highly dynamic driving profile can be readily seen from the velocity and engine speed traces. The filter inlet temperature is usually in the range of 200°C, which is well below the range where passive soot oxidation by NO₂ occurs. The two instances where the inlet temperature increases rapidly represent active regenerations. The lower curve again represents a normalized value from the soot estimation. This value increases during operation without any phases of passive regeneration and decreases during active regenerations.

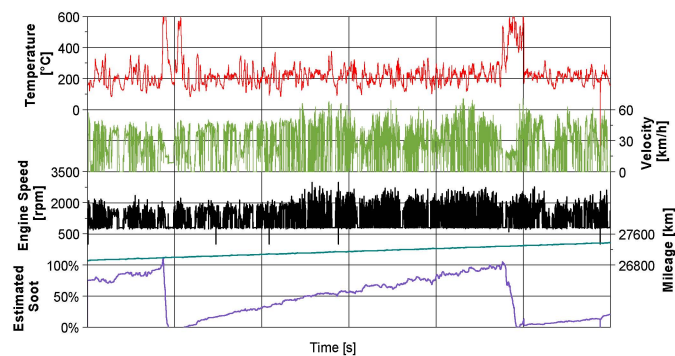

Figure 5. Example of a typical city driving profile with 25km/h average velocity.

Statistical average values characterizing the relevant engine and vehicle operation in the different driving cycles are summarized in Table 3.

Table 3. Statistical data from the driving cycles (mean values)

Parameter	Cycle		
	City	Highway	Mixed
Velocity / km/h	20-28	90-100	50-60
Engine Speed / min ⁻¹	1200 - 1450	1900 - 2100	1500 - 1700
Load factor / %	13-16	30-35	20-25
Idling Time / %	22-25	5-7	7-10
Overrun / %	10-13	15-18	15-18

The relatively low load factor, defined as average load divided by the maximum load (determined from the injection fueling rates) in city and our mixed cycle is obvious. This is likely to also influence the oil consumption and ash accumulation in the filter. Characteristic of the city driving is the high idling time, which represents almost a quarter of the operating time.

Operation was done during all seasons, including German winter and summer conditions.

Regular ultra low sulfur diesel fuel (<10ppm S) obtained at normal gas stations was used throughout the entire test. Regular maintenance inspections and oil change intervals, according to the car manufacturer's instructions were performed. Standard engine oil specified by the car manufacturer was used in all cases.

EMISSION TESTING

Emission testing was done directly after the installation of the filters as well as in regular intervals, usually every 20,000 to 30,000km. All emission tests were performed on a chassis dyno at a certified type approval facility over the New European Driving Cycle (NEDC). Legislated bag emissions for CO, CO₂, NO_x and HC+NO_x were determined as well as the particulate matter emissions (PM) using the standard gravimetric method. In addition to the bag emissions a two line emission bench was used to obtain information on the transient engine out and tailpipe emissions throughout the test cycle. All tests were performed as cold tests, according to the currently valid protocol with conditioning of the vehicle usually done overnight. In most cases, two tests on consecutive days were performed, although the agreement between both measurements was generally excellent. The emission tests have been performed with the particulate filters as they arrived. No filter conditioning with respect to the soot load by means of three extra urban cycles (EUDC) prior to the testing have been performed, as would have been allowed by the official test protocol.

INITIAL EMISSION TESTING RESULTS

As mentioned above all filters have been tested for initial emissions directly after the installation (<1000km of operation). A summary of the particulate emissions obtained in this initial emission test are given in Figure 6.

The error bars indicate the deviations between measurements, if more than one test was performed.

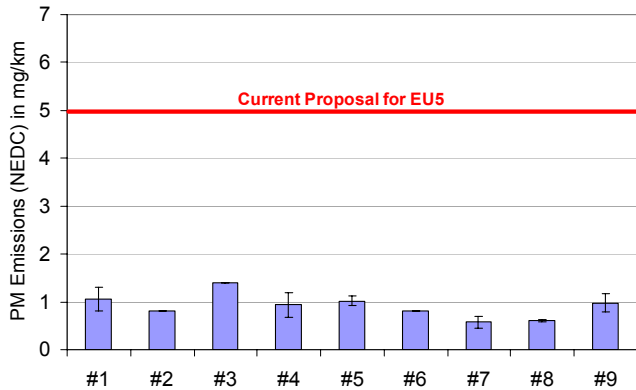

Figure 6. Initial PM emissions over the NEDC obtained with the 9 aluminum titanate filters included in the durability test.

In all cases the particulate matter emissions have been in the order of 1mg/km and significantly below the current Euro 5 proposal of 5mg/km.

The gaseous emissions are related to the catalyst coatings rather than the filter. Therefore, a detailed discussion is outside the scope of this paper. However, we can mention that all systems and vehicles were well within the EU4 limits.

DURABILITY EVALUATION IN A DOC PLUS CSF CONFIGURATION

For the evaluation of the durability of the new aluminum titanate filters in a system with an oxidation catalyst followed by the catalyzed filter two types of tests were performed. For both tests, vehicles were obtained with a series SiC filter and calibration (vehicle A & B). We replaced the SiC filter by an aluminum titanate filter with comparable catalyst coating and a series type canning prior to the testing. No modifications were made to the calibration. Since the aluminum titanate filters had more than 30-40% lower pressure drop, it was expected that potential issues might arise with respect to the pressure drop based soot estimation. This was confirmed in a set of experiments with vehicle B in which we have determined the actual soot mass by weighing of the filter twice a day over a period of 2 weeks. The comparison between the measured soot loadings and the values obtained from the ECU soot estimator suggested that the actual soot loads were sometimes off by more than a factor of two and soot loads up to 14g/dm³ have been observed in city operation. Although this shortcoming represented a potential risk, it had the benefit of representing a worst case scenario for our durability program.

OPERATION IN A TYPICAL DAILY COMMUNITING AND HIGHWAY TRAVEL DUTY CYCLE

With the exception of two tests over ~2000km each in city only operation, Vehicle A with Filter 1 was operated under typical German driving conditions including daily commuting as well as medium distance highway trips, i.e. as common for business travel within Germany. No limits were applied with respect to vehicle or engine speed. The commuting part has similar duty cycle characteristics as given in Table 3, but the highway travel operation is characterized by a somewhat higher mean engine speed of 2400-2500min⁻¹ at similar load factors of ~30-35%. This test has been performed without accelerated mileage accumulation over 60,000km and a period of 2 years. No problems have been observed during the operation of the vehicle. The typical regeneration distance was in the order of 900-1000km, indicating that the regenerations were primarily triggered by the distance criterion. The conditions during the two city tests mentioned above occurred without issues although the peak temperatures reached were slightly higher than during the normal cycle (with a maximum at 1140°C). Typical peak temperatures observed within the filter during this test were in the range of 600-800°C. Emissions have been stable, as shown in Figure 7, and always in the range of 1 mg/km.

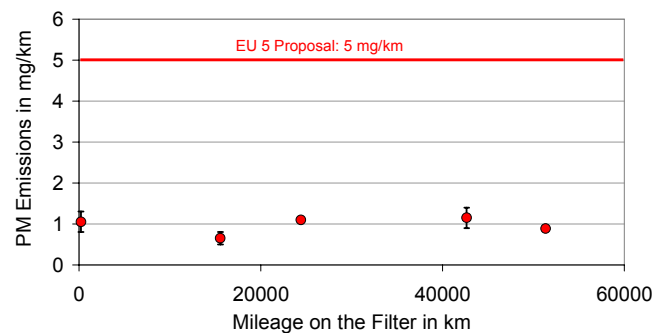

Figure 7. Particulate emissions (NEDC) determined with vehicle A and filter 1.

OPERATION IN A SEVERE DUTY CYCLE WITH SIGNIFICANT CITY OPERATION

The second type of test was performed with Vehicle B. The objective of these tests was to evaluate the filter performance in a fairly demanding duty cycle comprising significant extended city cycles. A schematic of the test is summarized in Figure 8.

The test was split into three blocks of 20,000km each, with the first and the last being identical. Both consisted of 4 repetitions of 3000km highway followed by 2000km in city only (for both duty cycles the restrictions described in the Experimental section applied). In total, 16,000km of city-only operation was accumulated during these two blocks with some additional 3300km in city operation during the mixed cycle of Block 2. Considering that the engine

calibration and soot estimator were not adjusted, this is viewed as a severe durability test. In total, 124 regenerations have been observed during the test. In Figure 9 a summary of the distribution of the recorded peak temperatures is given. Roughly 5% of the regenerations resulted in peak temperatures above 1000°C and the maximum recorded temperature was 1160°C. Another important aspect with respect to the thermal stress applied to a filter is the maximum temperature gradient that is created. Generally, we observe the maximum gradients in the radial direction, close to the skin. In the test with Vehicle B we have had a thermocouple pair located in the last cell from the skin and at 10mm inside, meeting the above described internal standard to determine radial temperature gradients.

Block 1	Block 2	Block 3
<ul style="list-style-type: none"> •Emission Test •3000km Highway •2000km City •3000km Highway •2000km City •3000km Highway •2000km City •3000km Highway •2000km City 	<ul style="list-style-type: none"> •Emission Test •CORNING Mixed Cycle: ⇒ 125km Extra urban ⇒ 40km Highway ⇒ 40km City ⇒ 40km Highway ⇒ Rerun 	<ul style="list-style-type: none"> •Emission Test •3000km Highway •2000km City •3000km Highway •2000km City •3000km Highway •2000km City •3000km Highway •2000km City •Emission Test
20000 km	20000 km	20000 km

Figure 8. Description of the test with vehicle B.

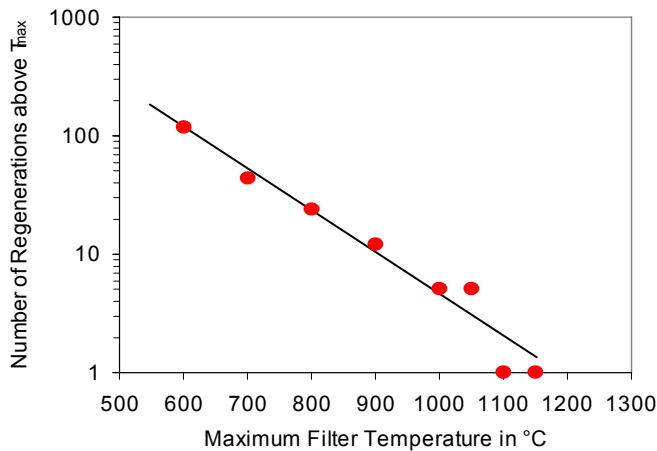

Figure 9. Frequency of regenerations above a certain peak temperature observed with vehicle B.

In Figure 10 the observed maximum gradients are plotted vs. the maximum temperature in the filter for all 124 regenerations. The color indicates during which driving profile the regenerations occurred.

Most regenerations occurred at maximum temperatures of 600-800°C with maximum gradients of 200-300°C. A few regenerations, however, reached higher temperatures and

gradients with values up to ~600°C/cm. Although quite high, and well outside the range where SiC would survive [7], we have generally not observed any crack formation or other degradation under such conditions. The emission test results shown in Figure 11, confirm that no loss in filtration performance occurred.

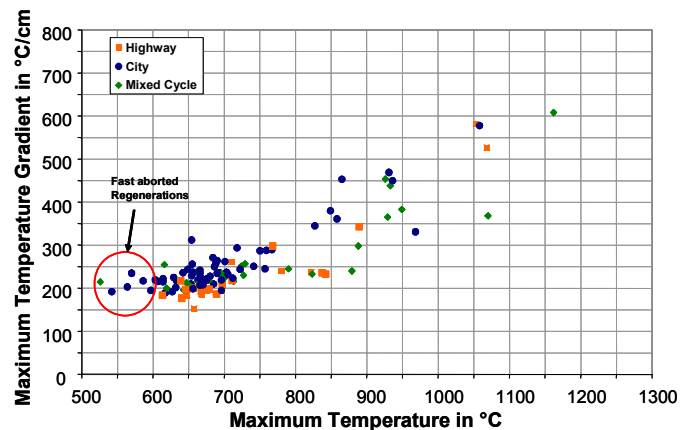

Figure 10. Maximum radial temperature gradients vs. maximum temperature observed during the test with Vehicle B.

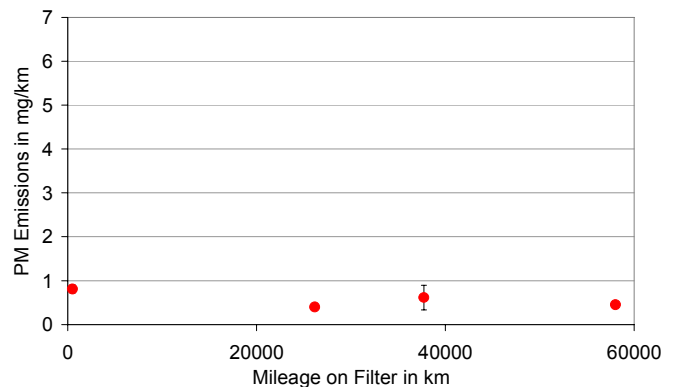

Figure 11. Emission performance during the 60,000km test with Vehicle B.

DURABILITY EVALUATION IN A CLOSE-COUPLED DOCSF CONFIGURATION

Focus of the tests with vehicle C-F and filters 3-9 in a close-coupled position with fully integrated oxidation function was to evaluate the long term durability performance of the new aluminum titanate filter in a "typical" operating profile. All tests were performed over our mixed cycle, described above. Different mileages were targeted, ranging from 90,000km to 240,000km, and emissions were monitored in regular intervals. After the test the filters were analyzed in detail for functional properties such as pressure drop as well as for material and integrity characteristics such as cracks, material changes, physical properties etc.

REGENERATION HISTORY AND EMISSION PERFORMANCE

In Figure 12 an example of the temperature traces inside the filter during a typical regeneration are shown (vehicle E, Filter 8). Shown are the thermocouple readings at different locations inside the filter (plane A and D in Fig. 3). The top diagram shows that a good temperature distribution across the entire inlet area was achieved. A relatively homogeneous temperature distribution is observed in the outlet plane, which helps to avoid extreme temperature gradients, leading to thermal stress in the filter body.

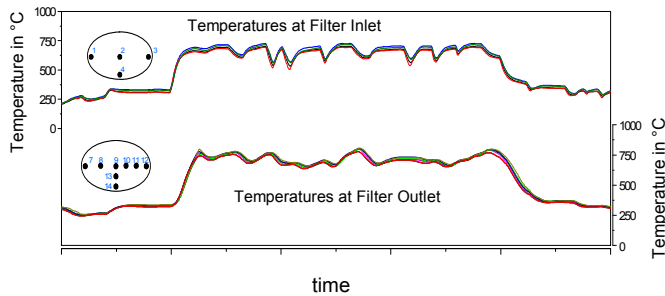

Figure 12. Example of a typical regeneration (vehicle E). Shown are the temperatures at different positions inside the filter. Top: inlet plane 25mm from front; bottom: outlet plane 25 mm from outlet.

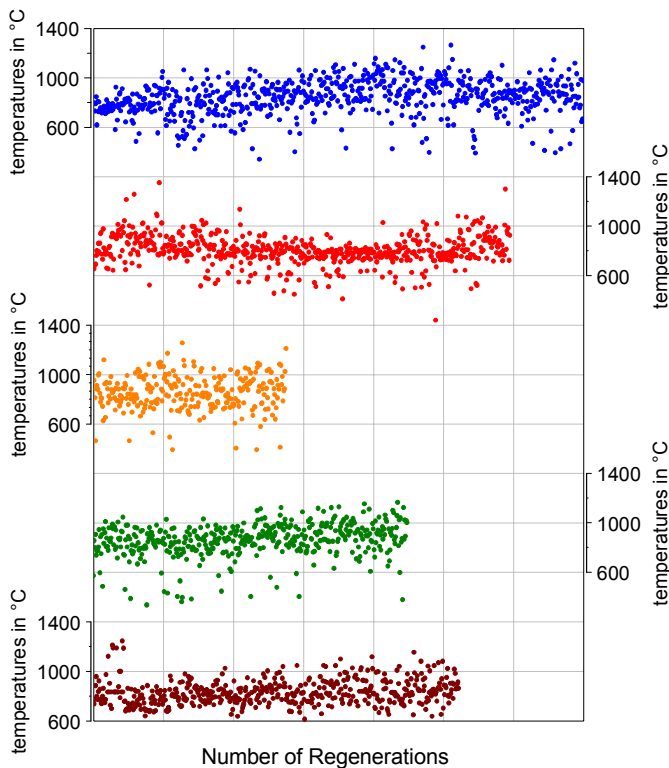

Figure 13. Peak temperatures observed in the filters 4, 5 and 7-9 during active regenerations (each data set / row represents one filter).

A summary of the peak temperatures observed in the durability tests with filters 4, 5, 7-9 is shown in Figure 13. It is worth mentioning that vehicles with a very early

calibration and hardware status had been used for the test with filter 4, 5 and 7. This, combined with our quite demanding mixed driving cycle, resulted in relatively frequent regenerations with a larger number of severe events. These severe events are not desirable for a production vehicle but are acceptable for an accelerated testing of the new aluminum titanate material.

From Figure 13 it can be seen that all filters have been exposed to several hundred regenerations. In addition, all filters have seen quite severe conditions. This is shown also in Figure 14, which summarizes the frequency of regenerations with peak temperatures above a certain threshold. From Figures 13 and 14 we see that in numerous cases, e.g. 5-15%, the peak temperatures were in excess of 1000°C. In a few cases, the peak temperatures have been as high as 1250-1300°C, representing less than 1%, but under these conditions every single event creates high stresses.

Since the aluminum titanate material is stable up to high temperatures the peak temperatures alone are not the most critical parameter, but one must consider the associated temperature gradients. Although the new stabilized aluminum titanate composition can handle extreme temperature gradients due to its unique combination of low thermal expansion, low E-modulus and good strength [1-3], excessive thermal stresses can eventually lead to the formation of cracks. In Figure 15 we have summarized the radial temperature gradients observed on Filter 9. Shown are data collected at different circumferential locations in the oval shaped filter and plotted vs. the maximum temperature observed in the filter during the corresponding regenerations.

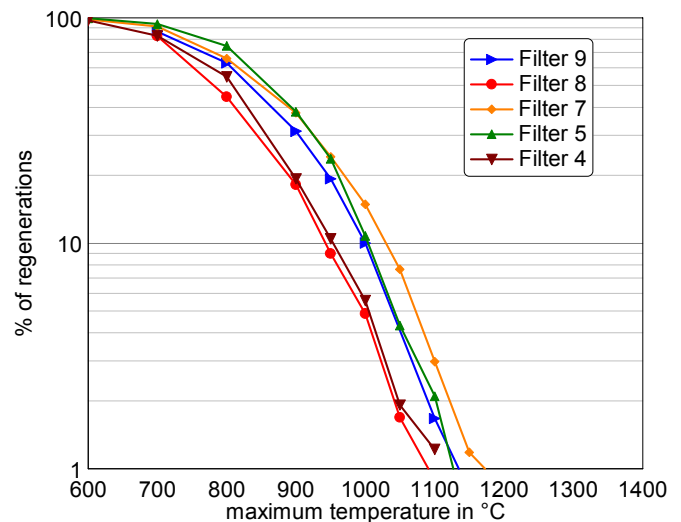

Figure 14. Frequency of regenerations above a certain peak temperature observed with the different filters (colors indicate the different filters).

Several observations can be made from these data. Firstly, we have observed a reasonably good temperature distribution across the entire filter, which is represented by the gradients and peak temperatures at all locations

considered. Secondly, we observe a correlation between the peak temperature and the maximum radial temperature gradient, i.e. the gradients are higher if the peak temperature is higher. This behavior is expected, as the skin temperature can be assumed to be similar for all cases, so that the gradient directly scales with the temperature in the core of the filter. The correlation also fits very well with data that we have observed in extensive engine bench test programs. Based on this experience we would expect to see some minor crack formation for the regenerations with temperatures in excess of 1250-1300°C. However, in the emission tests performed continuously and in regular intervals we have not observed any change in filtration performance, as is shown in Figure 16. In all cases the emissions obtained over the NEDC were very low and in the range of 1mg/km, as we have observed for the new filters. This includes filters 8 and 9, which have been operated over 240,000km, with filter 8 having been exposed to at least two events with peak temperatures in excess of 1300°C (see also Fig. 13). More detailed discussion on the analysis of the filters after the tests will be provided below.

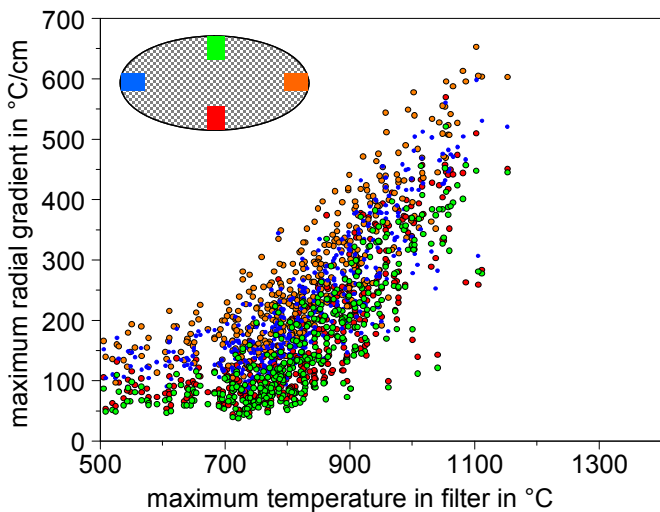

Figure 15. Maximum radial temperature gradients vs. maximum temperature observed during the test with filter 9.

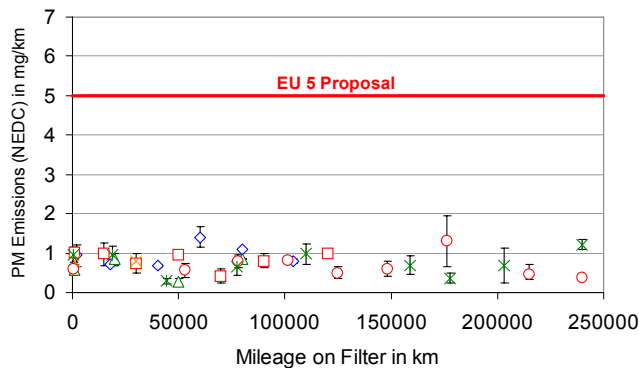

Figure 16. Emission performance obtained with the different vehicles and filters in the durability program.

PRESSURE DROP BEHAVIOR

In addition to the thermal exposure a filter experiences during use and the requirements with respect to emissions, another important characteristic is the pressure drop response in an ash loaded state. As mentioned above the filter does not only collect the soot emitted by the engine but also the inorganic particles, which are commonly referred to as ash. The ash particles have a different origin, with the bulk coming from the oil and fuel. Since the inorganic particles can not be burned during regeneration they remain in the filter and accumulate over its life. Although it will depend on the actual engine operation, the current understanding is that in most cases the bulk of the ash will be deposited as a plug in the rear of the filter. As the ash consumes some space and filtration surface area it can have an impact on the pressure drop response of a filter. This can be important with respect to the backpressure and its impact on fuel consumption as well as on the estimation of the soot load based on the filter pressure drop.

In our durability test program filter 7-9 all had the asymmetric cell technology (ACT) for enhanced ash storage capacity (s. Fig. 1). Generally, the real benefit of such a feature can only be determined if a sufficient amount of ash has been accumulated and the filter was operated over a long distance [3, 6]. Assuming an ash accumulation rate of 0.48mg/km, as given in reference [8], the expected ash mass after 100,000km would be ~50g or ~15-25g/dm³, based on the volume of filters 4-9. Assuming that the bulk of the ash is deposited in the rear of the filter this would correspond to an ash plug length of 15-30mm, depending on the ash density and the cell design (with the shorter values for the asymmetric cell technology). The post test analyses of filters 4, 5 and 7 confirmed this range for the ash deposits. The differences observed in the pressure drop analysis between the standard and the ACT filter were within the range of experimental uncertainty and could also be explained by differences in the ash accumulation or the ash density, the latter being determined by the thermal history of the ash and sintering. A clear benefit of the ACT design is expected to become more evident at somewhat higher ash loads in the range of 25 g/dm³ or more [3, 6]. Ash accumulation at such a level is expected for operation up to 160,000km, representing the expectations for in-use compliance requirements of the EU5 legislation, or even up to 240,000km, as frequently used design target of OEM's. Therefore, to evaluate the benefit of the asymmetric cell technology a detailed analysis has been performed on filter 8, which has been operated over such a long distance of 240,000km.

In Figure 17 the "clean" pressure drop of the filter as measured on the vehicle is shown as function of the volumetric flow rate. Data are shown from the start of the test as well as after 70,000km, 150,000km and 210,000km. The pressure drop values for a clean filter were collected just after successful active regenerations

with good regeneration efficiency. Due to the significant scatter of the experimental data caused by the transient vehicle operation, we have also added a graph in which the data are compared based on trend lines fitted to each of the data sets. From these experimental data it becomes evident that no change can be observed in the clean pressure drop behavior over the course of the test.

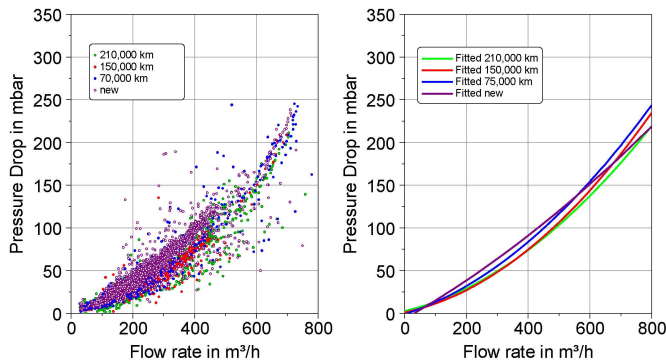

Figure 17. Comparison of the “clean” pressure drop determined on vehicle E with filter 8 at the beginning and after 70,000km, 150,000km and 210,000km. (note: clean is defined as shortly after an active regeneration). Left: measured data; right: trend lines fitted to experimental data.

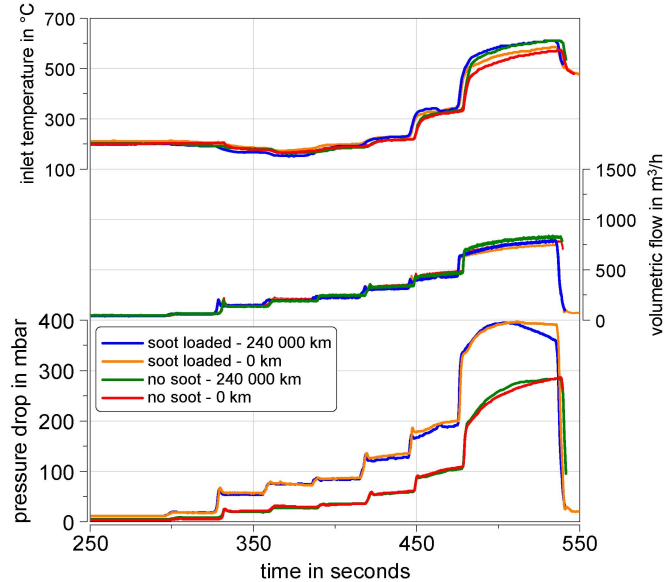

Figure 18. Pressure drop measured with filter 8 on engine bench prior to and after the test over 240,000km. Shown are the flow conditions as well as pressure drop data from tests with the fully regenerated filter and the soot loaded filter.

To further evaluate the pressure drop behavior, the filter was also tested on engine bench. The engine bench tests were performed with filter 8 before and after the vehicle test on the same type of engine as installed on the vehicle. Exactly the same procedures were used in both cases. In the engine bench tests the clean pressure drop as well as the soot loaded pressure drop was measured. The results of these tests are shown in Figure 18. In addition to the pressure drop data we have also included the filter inlet temperature and volumetric gas flow during the test to show the good reproducibility of the test conditions. The pressure drop test consisted of a number of engine operating points with different engine speeds and loads. The comparison of the clean pressure drop data obtained on the engine bench (lower two green and orange lines in Fig. 18) confirms the observations made with the vehicle instrumentation. No difference can be observed between the new and aged filter. These data, if plotted vs. the volume flow, also match exactly the pressure drop data obtained on the vehicle (e.g. Fig. 17). The comparison of the results from the pressure drop tests with a soot loaded filter also show no significant change in the pressure drop behavior. These excellent data support the concept that the ACT design offers a clear benefit with respect to extended life time pressure drop performance under real operating conditions and also confirm the observations made in lab and engine bench studies reported by Heibel et al. [3, 6].

Further evidence of the pressure drop performance of the aluminum titanate filter with ACT technology can be obtained from the fuel consumption data. To have reliable and repeatable conditions we evaluated the fuel consumption values determined via gas analysis during the emission tests over the New European Driving Cycle. In general, we observed that these values match nicely with the measured on-road fuel consumption during our mixed cycle operation. The fuel consumption is determined for the two phases of the emission cycle, the urban phase and the extra urban phase as well as for the entire NEDC cycle. In Figure 19 results are shown for filter 8 and 9 and vehicles E and F, respectively. Both vehicles have the same engine and similar weight. No changes in fuel consumption can be observed, as one might have expected as result of an increased back pressure. For both vehicles and filters constant values have been found throughout the entire test over 240,000km. This confirms the observations made in our pressure drop experiments regarding the benefit of the ACT design.

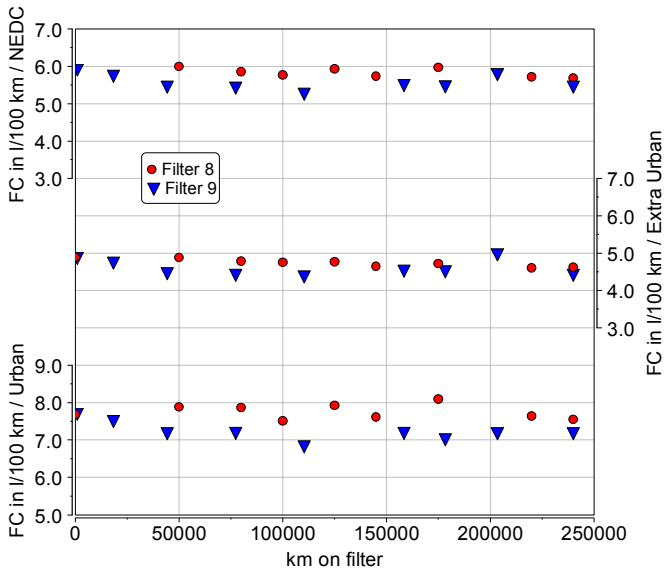

Figure 19. Fuel consumption (FC) observed during the course of the durability test with filter 8 and 9. Data measured during emission test on the roller bench over the NEDC cycle.

POST TEST ANALYSIS

After the on-road durability tests most of the filters have been analyzed in detail with respect to potential mechanical damages or changes in physical properties. For this purpose the filters were first removed from the canning and evaluated for any visual defects.

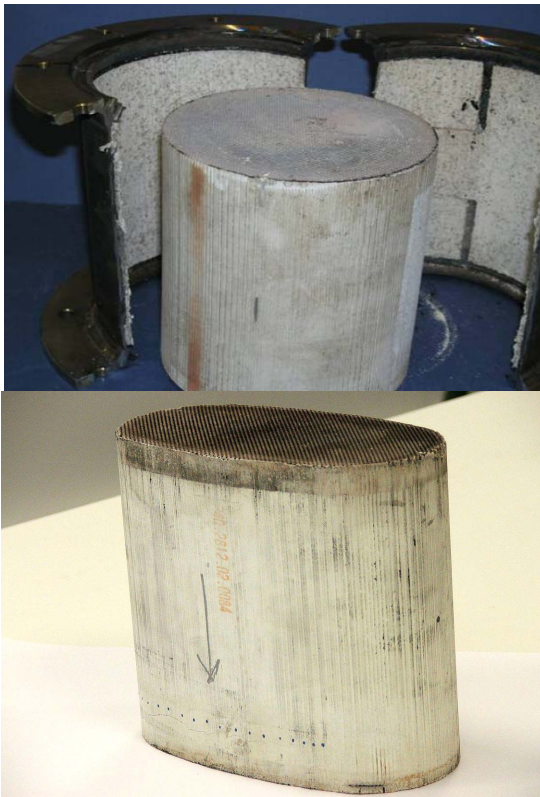

Figure 20. Pictures of filter 4 (top) and 8 (bottom) after the test over 105,000km and 240,000km, respectively, and removal from the canning.

Photos are shown in Figure 20 of two filters directly after the de-canning (note: that the flanges on the canning of filter 4 have been added after the vehicle test to be able to run some engine bench and lab tests). Both of the filters in Figure 20, as well as all the other filters analyzed, have been found to be in good condition. Before the destructive analysis of the parts, a computer tomography (CT) scan was typically acquired to get some insight into the ash deposition inside the filter channels as well as to identify other potential changes. In Figure 21, an example of a CT scan is given for filter 8, representing the situation after 240,000km of operation. The deposition of ash in the rear is clearly visible. From the contrast it can be noticed that ash density is varying along the “ash plug” (e.g. light image represents high density). For each “ash plug”, there is a high density ash region just above the outlet plug, then a lower density ash region and finally a high density ash region. These two, high-density ash regions are possibly explained by the two high temperature regeneration events (>1300°C) experienced by this filter at the beginning and at the end of on road testing (see Figure 13). Similar temperatures were experienced inside the SiC filter originally tested on this vehicle. The ash plugs in the rim region do not show this high density, sintered ash. This is explained by the lower temperatures in this region. It is expected, that the ash plug lengths in this rim region are more representative of the volume covered by ash after 240,000km with the ACT filter design and operation of such a vehicle without high temperature regenerations.

Further CT scan image processing allows visualization of the ash distribution in some cross-sectional slices (see Figure 22). These images show that ash distribution is symmetric. In addition, as already seen in Fig. 21 it appears that the length of the “ash plugs” is shorter in the entire center of the filter, as a result of ash sintering.

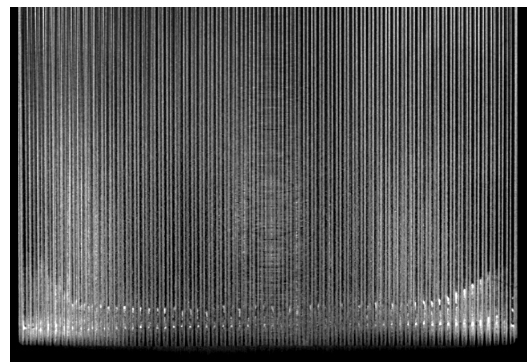

Figure 21. Computer Tomography scan of the rear of filter 8 after 240,000km of on-road testing. Shown is the bottom part of the filter, cut along the long axis of the oval filter.

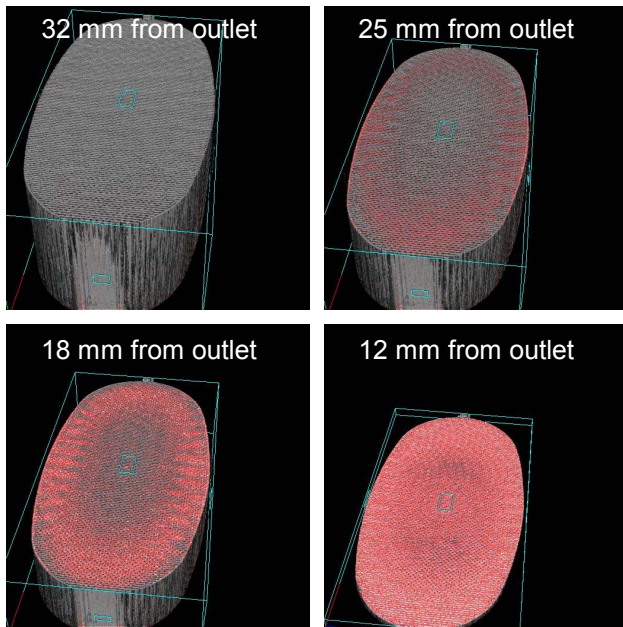

Figure 22. Computed Tomography scan of the rear of filter 8 after 240,000km of on road testing. Shown are radial slices at various distances from the outlet face, with ash shown in red.

After the non-destructive part of the analysis, the filters are usually cut into two halves to get insight into the filter interior. This is shown in Figure 23 for the example of filter 5, which operated over 120,000km with several hundred regenerations (see Fig. 13). No major mechanical defect can be observed. In the bottom section the ash can be identified above the plugs. However, since some ash is removed during the cutting, this method is not suited for a quantification of the ash deposit



Figure 23. Pictures of filter 5 after 120,000km of operation and several hundred regenerations. Picture shows the inside of the zone-coated filter after de-canning and cutting into two halves. Filter inlet is at the top.

In a further step, a slice of the filter is cut and separated into several bars. This allows identifying even very small, hairline cracks that were not visible before, as they would only open if all the holding forces are released. Based on our extensive experience from severe engine bench test programs, we would only expect to see such anomalies

for filters which experience very high thermal gradients (usually associated with temperatures $>1200^{\circ}\text{C}$). No cracks have been observed, if the temperature within the filters was maintained below 1200°C throughout the test. A few hairline cracks were observed after sectioning, on the exterior rim near the rear of some samples, which exceeded 1200°C . These anomalies only extend a few millimeters into the filter body without impact on the mechanical integrity or the filtration performance. This is in stark contrast to the severe cracking observations from the SiC filters (several cracks across each segment) removed from some of these same vehicles.

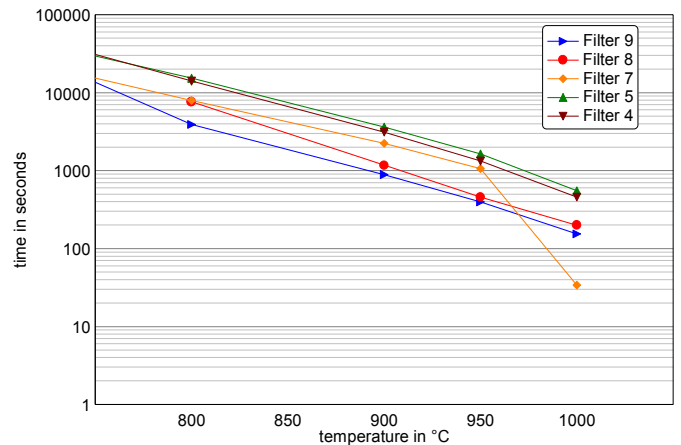

Figure 24. Time the hottest location in the filter spent above a certain temperature throughout the entire test.

With respect to any potential changes in the material properties or interactions with ash or other deposits the time the filter material spent above certain temperatures is of relevance. In Figure 24, the integral time-temperature history is given for the filters tested. In all cases the data are given for the thermocouple that recorded the highest temperatures. In addition to this we also have information about the history at the other locations.

The data in Figure 24 represent results accumulated over almost 700,000km on several vehicles and filters. In no case have we observed that any filter has spent more than 600 s above a temperature of 1000°C , with more typical values to be expected in the range of 100-300s over the entire filter life. This shows that most of the material evaluations done during the development, e.g. ref. [1], with exposures in the range of hours have been quite conservative.

To further evaluate the material behavior during such a long operation, physical properties have been determined for the filters tested. If available, reference data were collected on sister samples with comparable catalyst coatings. The physical properties measured are notably strength, which is best indicated as Modulus of Rupture (MOR), the Coefficient of Thermal Expansion (CTE) and the Young's Modulus (E_{mod}) in order to obtain a complete view of the thermo-mechanical

properties. In Figure 25 such data, obtained on filters 5 and 7 after the testing, are shown in the form of a so-called thermal shock parameter (TSP), which combines the relevant thermo-mechanical properties into a single value. Generally, the higher the TSP the better is the resistance to thermal stresses. For reference we also added the value provided in ref. [1]. As both filters are zone coated, the values are given for the inlet and outlet section separately. The inlet section typically experiences less demanding thermal stresses compared to the outlet of the filter. As can be seen from Figure 25, all values are comparable (or better) to the TSP provided in ref. [1] for a fresh and uncoated aluminum titanate filter. They are also significantly higher compared to the TSP obtained for SiC filters, which are in the range of TSP = 140 [1].

The filters were also analyzed by XRD to identify any changes in the material. The analysis provided no indication that such changes have occurred during the long and extreme exposure.

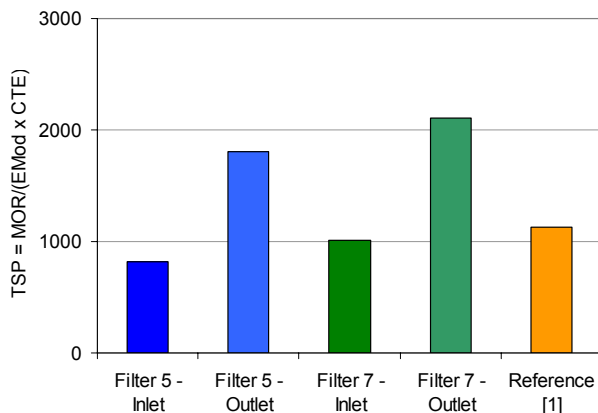

Figure 25. Thermal shock parameter TSP = MOR/(E-Mod x CTE) of the aged filters 5 and 7 after ~100,000km and several hundred regenerations. For reference the value given in ref. [1] is shown.

CONCLUSION

The new aluminum titanate diesel particulate filter has been extensively tested in a fleet evaluation with multiple vehicles and filters (with multiple coaters). Different system architectures and driving patterns were investigated. The filters were exposed to a large number of regenerations, some of which represented severe conditions. These filters have proved to be very robust, extremely durable and have shown excellent emission performance over the entire test, with PM emissions over the NEDC in the range of 0.5-2 mg/km. The ACT filter design also allowed for excellent pressure drop stability over a very long operation of 240,000km.

ACKNOWLEDGMENTS

The authors want to thank Achim Heibel and Dr. Willard Cutler for many fruitful technical discussions and their support. The authors also want to thank Connie Sawyer for performing the post test analysis on some of the filters.

REFERENCES

1. S.B. Ogunwumi, et. al., "Aluminum Titanate Compositions for Diesel Particulate Filters," SAE 2005-0100583
2. T. Boger, et. al., "Evaluation of New Diesel Particulate Filters," MTZ 66 (2005)
3. A. Heibel et. al., "Performance and Durability Evaluation of the New Corning DuraTrap AT diesel Particulate Filter – Results from Engine Bench and Vehicle Tests," 14 Aachener Kolloquium Fahrzeug und Motorentechnik 193-218 (2005)
4. Kercher L. et al., "Application of a New Filter Material in Volkswagen's Diesel Particulate Filter Systems". 3rd Emission Control Conference, Dresden 2006.
5. Yound D., et al. "Ash storage concept for diesel particulate filters", SAE 2004-01-0948
6. Heibel A. and R. Bhargava, "Advanced diesel particulate filter design for lifetime pressure drop solution in LD applications", Paper 07SFL-60 submitted to SAE Fuels & Emissions (2007)
7. Mizutani T., et al. "The study for structural design of the segmented SiC-DPF", SAE 2006-01-1527
8. Cipolla G. et al.; Diesel particulate filters – Field experiences with current systems and factors that will define future design. 27. Int. Wiener Motorensymposium (2006), 303

DEFINITIONS, ACRONYMS, ABBREVIATIONS

PUI: Pump Unit Injection

CR: Common Rail

CTE: Coefficient of thermal expansion

DOC: Diesel Oxidation Catalyst

DOCSF: Catalyzed Soot Filter with full oxidation functionality

CSF: Catalyzed Soot Filter

Emod: Youngs modulus

FIS: Fuel Injection System

FC: Fuel consumption

MOR: Modulus of rupture

TSP: Thermal shock parameter = MOR/(E-Mod x CTE)